



# Unit-IV

## *Vehicle Performance Parameters and Noise Vibration*

By,  
Mr. A J Bhosale  
Asst. Professor  
Dept. of Automobile Engineering  
Govt. College of Engineering and Research, Avsari (Kd)



## ❖ Introduction:

**Vehicle testing** is a procedure mandated by national or subnational governments in many countries, in which a vehicle is inspected to ensure that it conforms to regulations governing safety, emissions, or both.

## ❖ Vehicle Performance Parameters:

1. Fuel Economy
2. Acceleration
3. Top Speed
4. Ride Comfort
5. Handling Characteristics etc.



## 1. Fuel Economy

- The **fuel economy** of an automobile is the fuel efficiency relationship between the distance traveled and the amount of fuel consumed by the vehicle.
- Consumption can be expressed in terms of volume of fuel to travel a distance, or the distance travelled per unit volume of fuel consumed. (kmpl, mpg etc.)
- Since fuel consumption of vehicles is a significant factor in air pollution, and since importation of motor fuel can be a large part of a nation's foreign trade, many countries impose requirements for fuel economy.
- Different measurement cycles are used to approximate the actual performance of the vehicle. (**Corporate Average Fuel Economy (CAFE)** )



- The energy in fuel is required to overcome various losses (wind resistance, tire drag, and others) in propelling the vehicle, and in providing power to vehicle systems such as ignition or air conditioning.
- Various measures can be taken to reduce losses at each of the conversions between chemical energy in fuel and kinetic energy of the vehicle.
- Driver behavior can affect fuel economy; maneuvers such as sudden acceleration and heavy braking waste energy.
- CAFC( Corporate Average Fuel Consumption) norms have been proposed in India in April 2017.

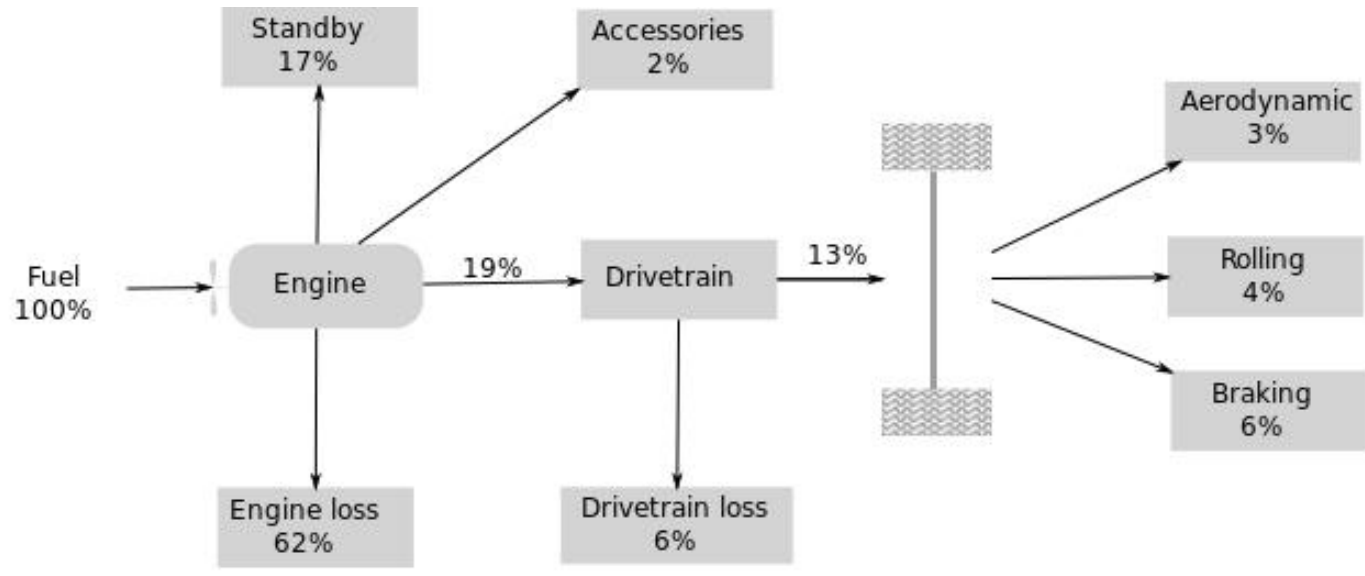

### Urban driving

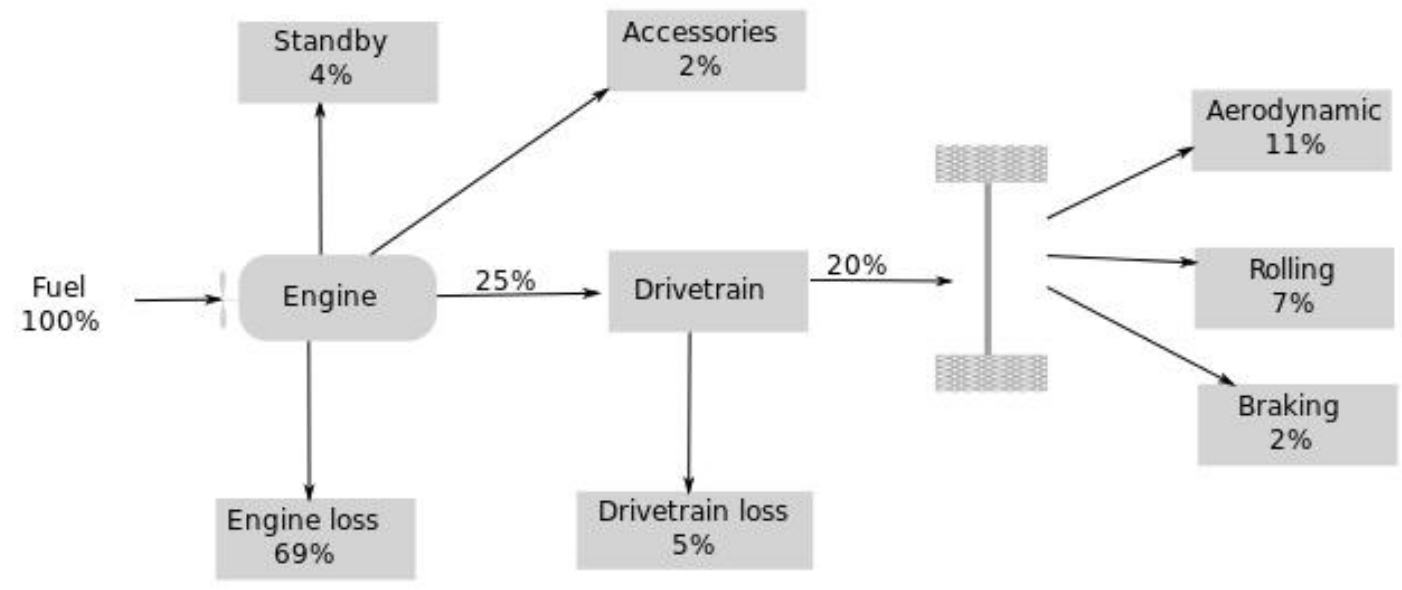

### Highway driving



The fuel economy of an automotive vehicle depends

1. The fuel consumption characteristics of the engine,
2. Transmission characteristics,
3. Weight of the vehicle,
4. Aerodynamic resistance,
5. Rolling resistance of the tires,
6. Driving cycle (conditions), and
7. Driver behavior

# Role of CAFE Standards

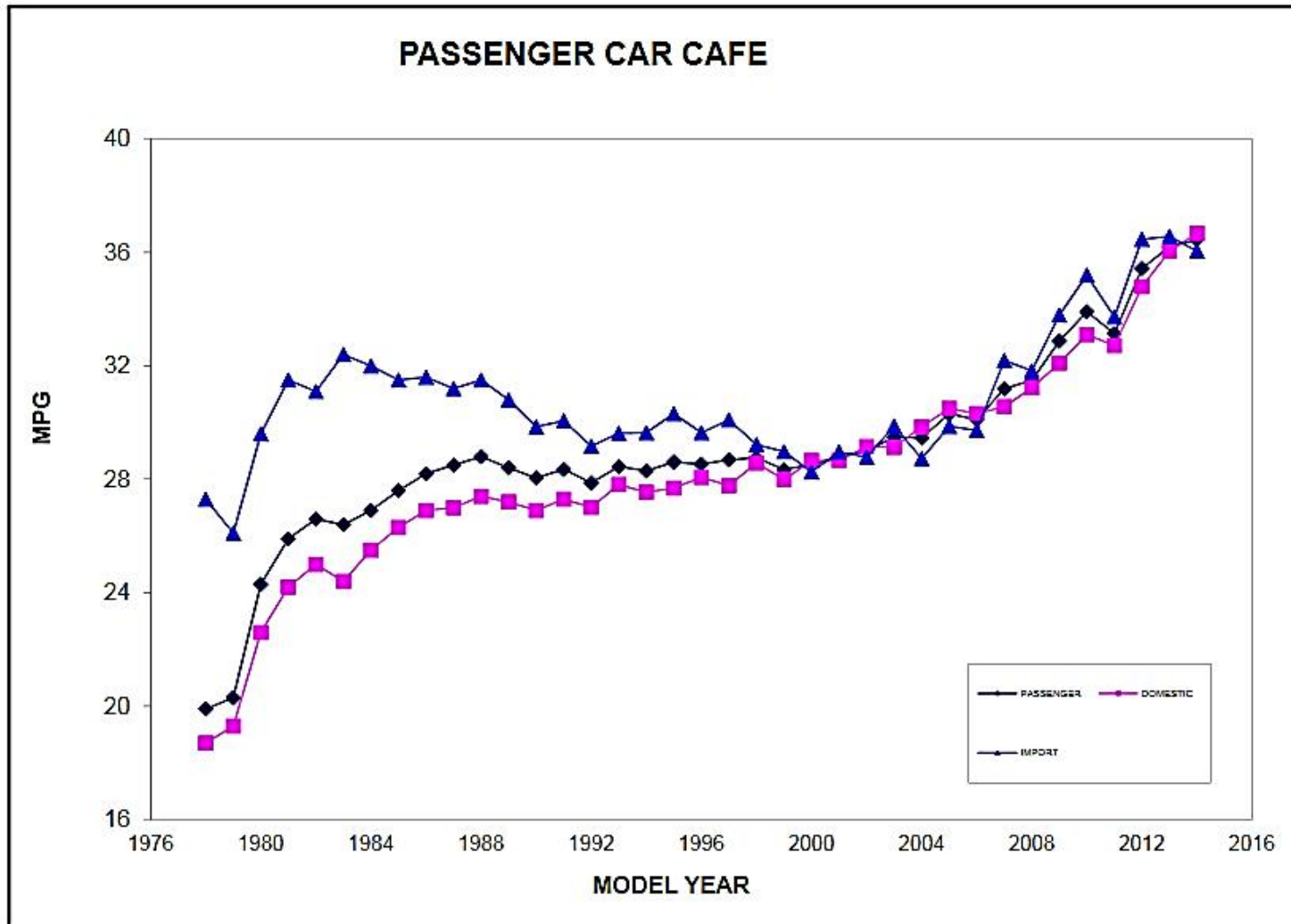

## ❖ Indian Scenario:

- Though vehicle stock is expanding rapidly in India there is no policy to mandate for fuel economy improvement for the vehicle industry.





## Indian Scenario:

More than a million vehicles in most of the leading developed cities in India

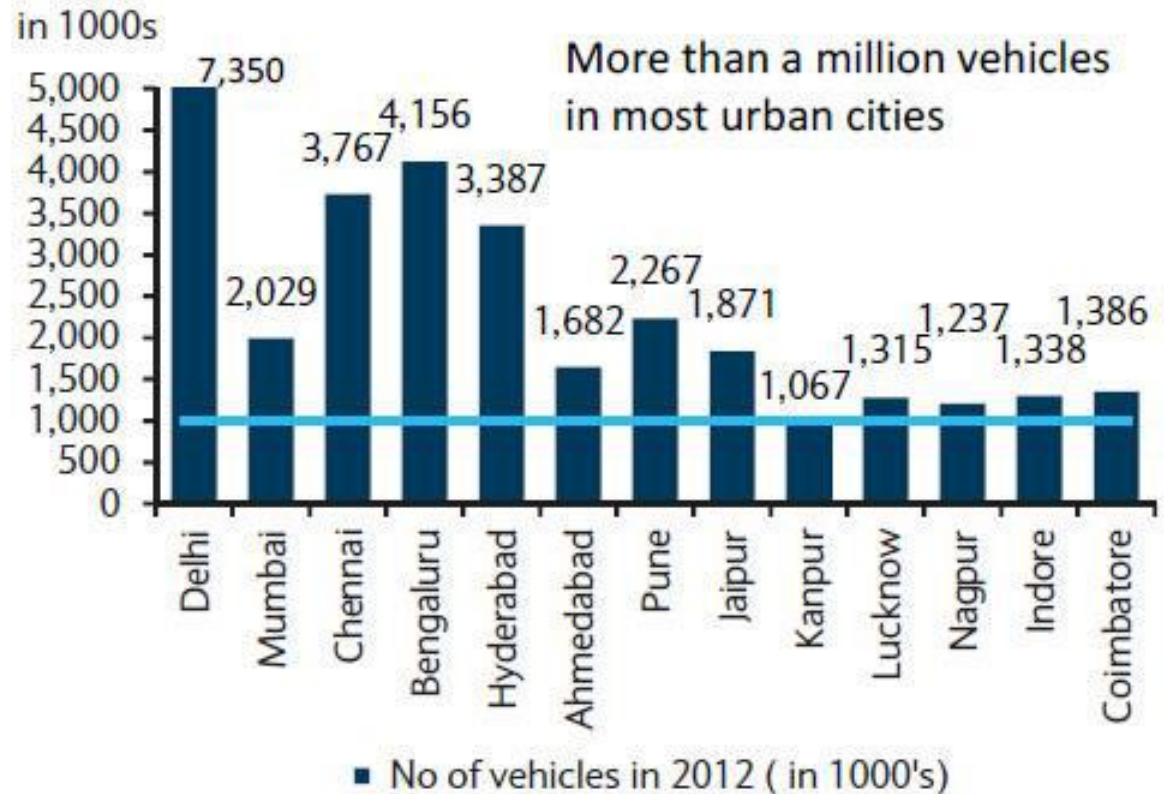

Source: MORTH, Barclays Research

## ❖ Fuel economy characteristics of a gasoline engine

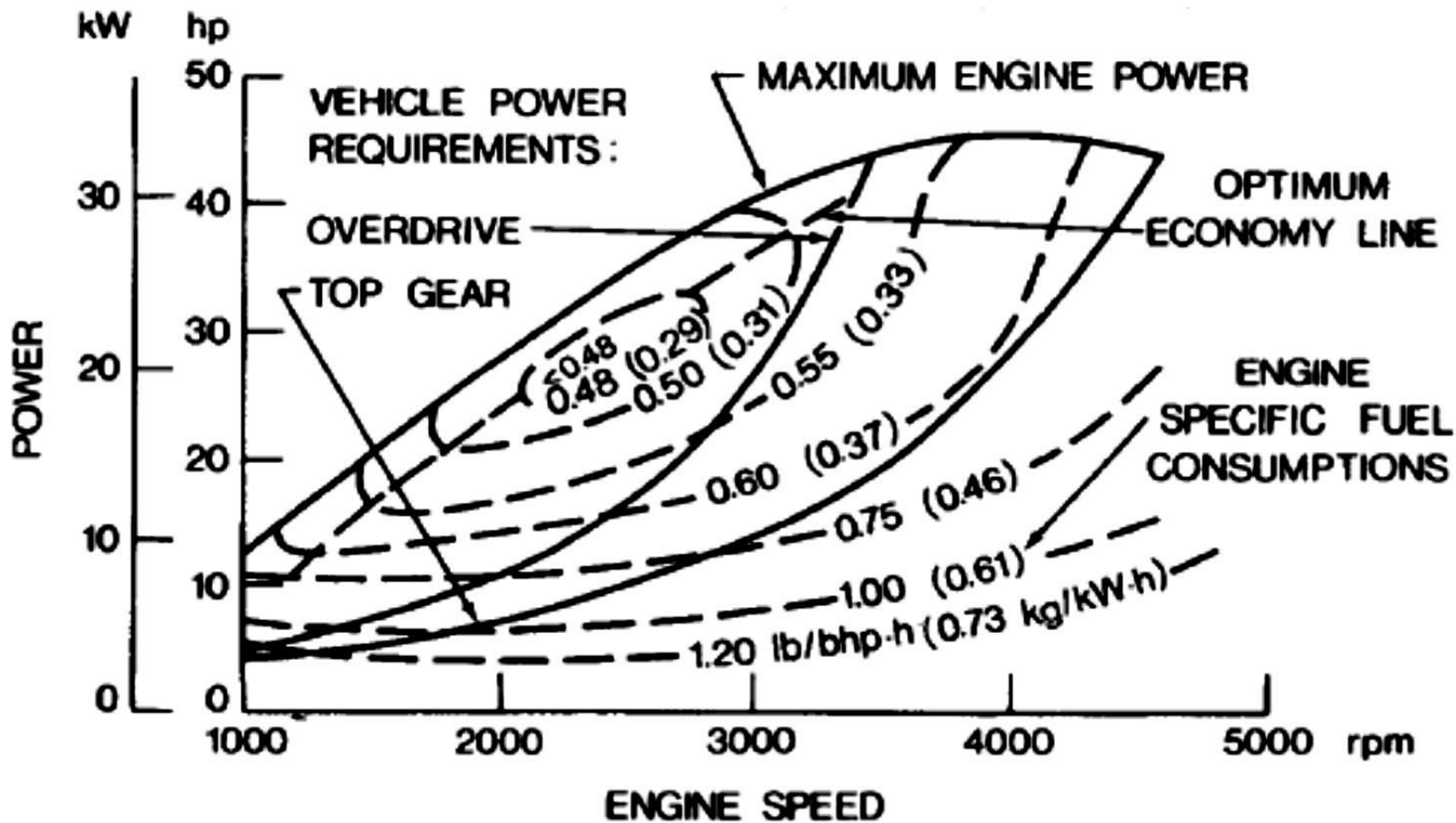

- The optimum economy line is obtained by joining the lowest sfc operating points for each power settings.



- Low fuel economy at low throttle and low torque.
- Engine gives higher fuel economy when it is operated at **low engine speed** and **high engine torque** than higher speed and low torque.
- For instance, an engine to produce 22 kw (30 hp) power, it can run at 2500 rpm or 4000 rpm.
- For 2500 rpm sfc is approx. 0.29 kg/kW.h and
- For 4000 rpm, sfc is approx. 0.37 kg/kW.h

# Fuel economy characteristics of a diesel engine

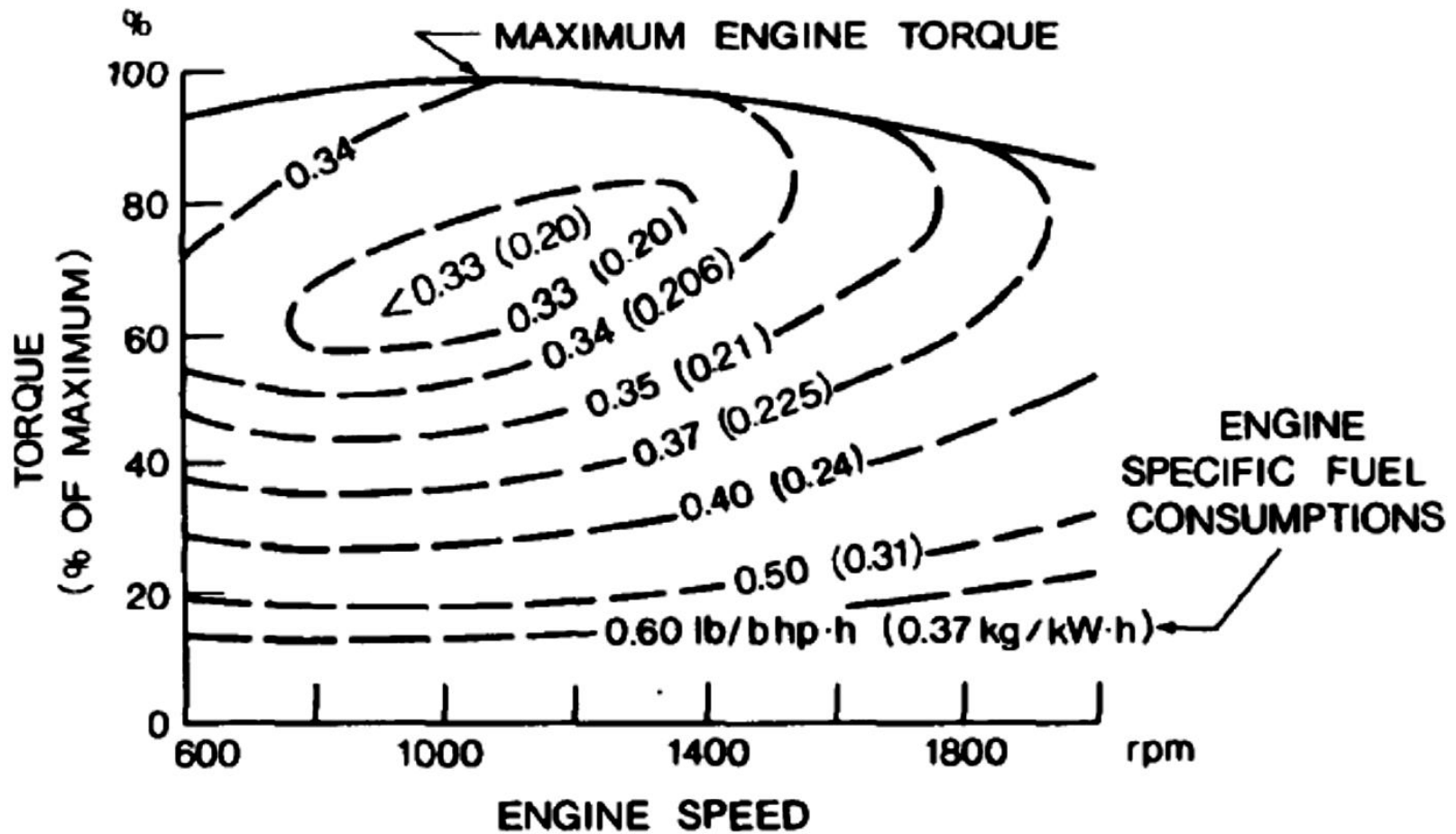

## Effect of Gear shifts on fuel consumption:

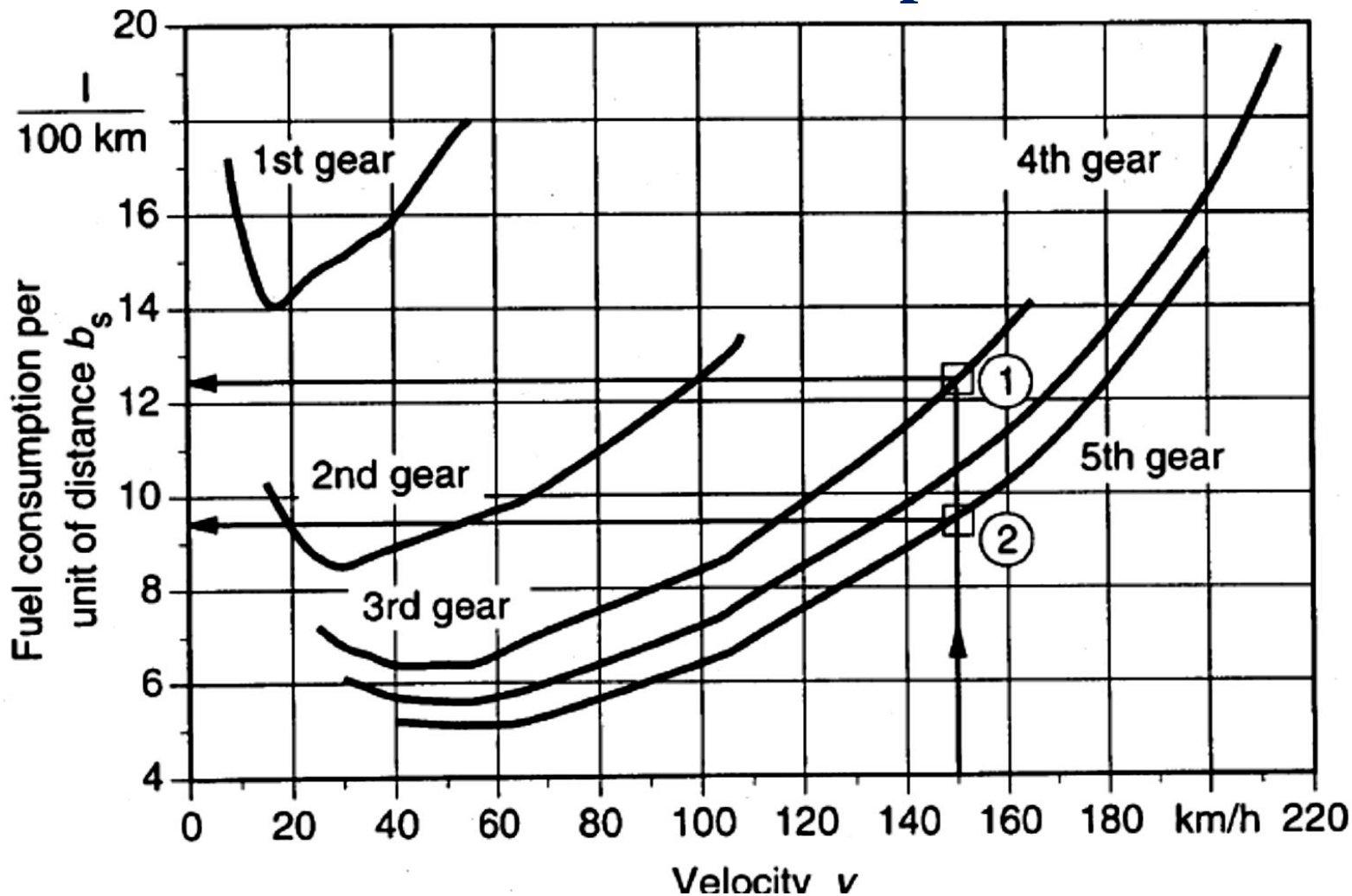



- In each gear there is speed at which fuel consumption is optimal.
- The driver can thus have a decisive effect on a fuel economy by his gear selection and timing of gear shifts.
- Because air resistance increases as the square of speed, the power requirement and thus fuel consumption increases at higher speed.
- The transmission should be of continuous variable type so that the engine can be operated under most economical conditions.



## Effect of Transmission on Fuel Economy

- CVT gives better FE in 60-150 kmph than manual trans. but due to its lower mechanical efficiency (86-90%) the characteristics are observed same as manual trans.

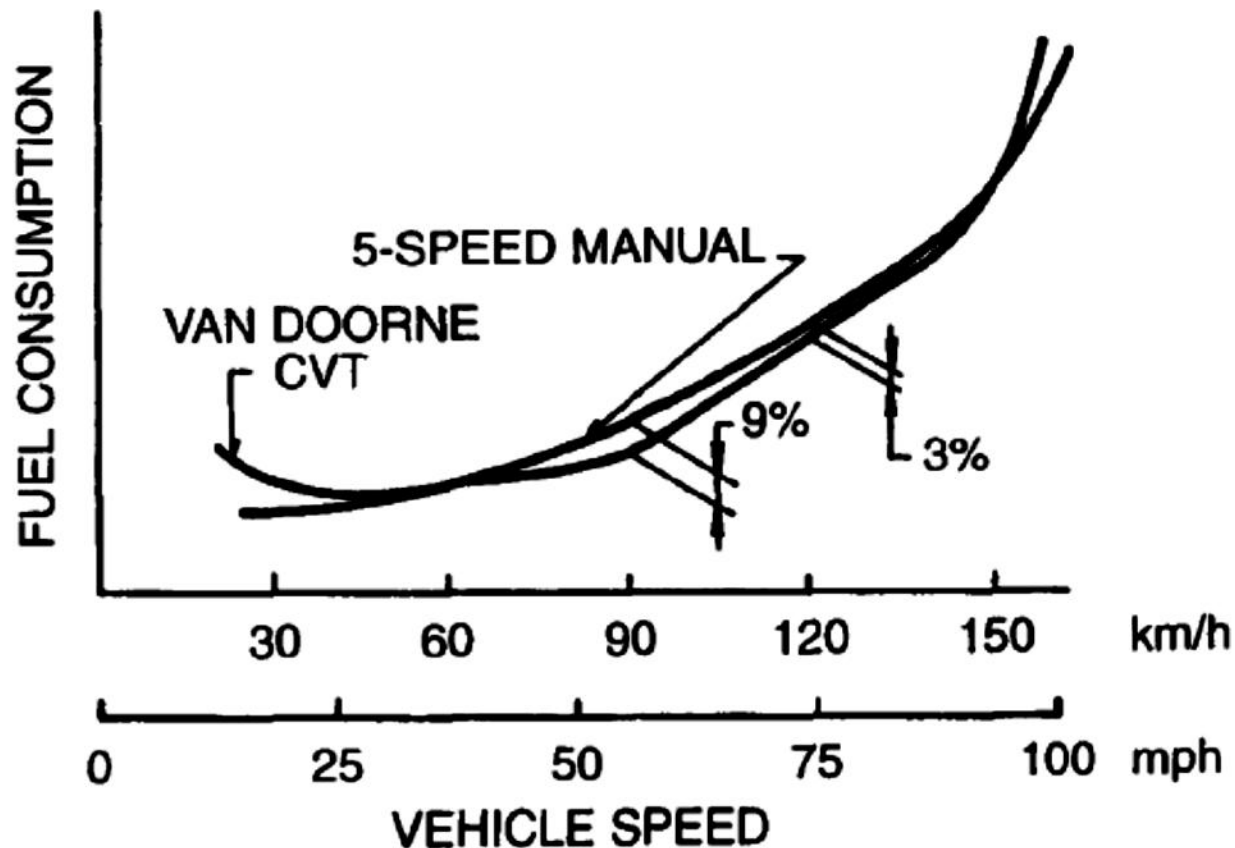



## CAFE Test Procedure:

- Consists of City driving cycle and highway driving cycle.
- City driving cycle- 10 “stop and go” in 766sec with max speed 96 km/h.
- Highway driving cycle- four segments (various roads) in 765 sec with max speed 96 km/h

$$\text{mpg}_{\text{composite}} = \frac{1}{(0.55/\text{city mpg}) + (0.45/\text{highway mpg})}$$



## European Driving Cycle:

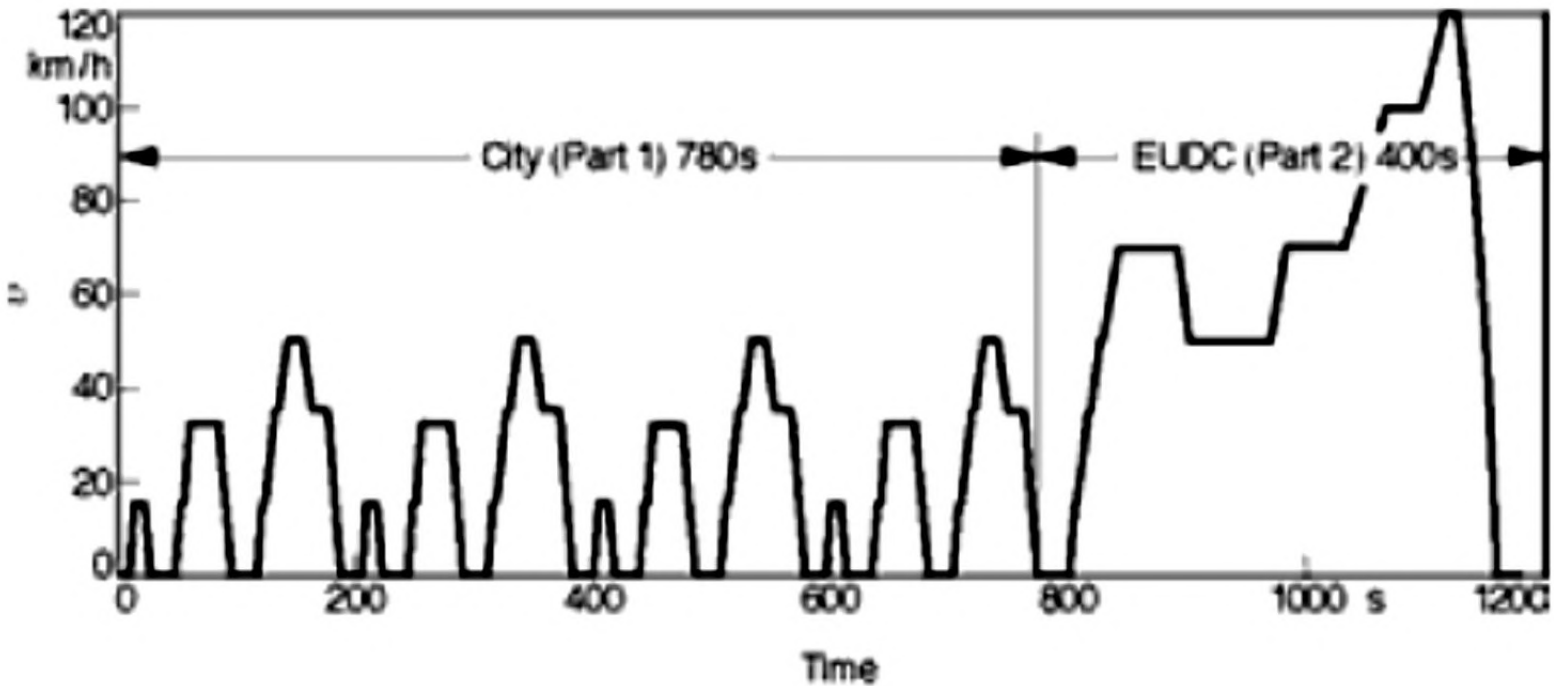

**New European Driving  
Cycle NEDC (93/116/EEC)**



- The New European Driving Cycle (NEDC, 93/116/EEC) is a cycle run on a dynamometer to ascertain fuel consumption.
- It consists of four similarly weighted urban cycles each lasting 195 s and an extra-urban cycle lasting 400 s.
- The exhaust gas is collected in a sample bag and its components subsequently analyzed. CO, HC and CO<sub>2</sub> are factored into the calculations in accordance with the carbon analysis.
- The CO<sub>2</sub> content of the exhaust gas is proportional to the fuel consumption.
- It can therefore be used as an indicator to gauge the vehicle's fuel consumption (diesel or gasoline, as appropriate).



## **Reducing Fuel Consumption:**

1. Improving the efficiency of the IC Engine particularly reducing the part load condition
2. Appropriate engine performance characteristics, i.e. vehicle must be neither over-powered nor under-powered
3. Reducing driving resistance, for example- rolling resistance and drag.
4. Improving the efficiency of the transmission (CVT)
5. Adaptive control of ratio selection by automatic selection circuits and CVT
6. Traffic management systems to reduce stationary periods
7. Improved driving, intelligent control systems.



## 2. Acceleration:

- Acceleration is defined as the rate of change of velocity in both magnitude and direction measured in time limit or interval.
- Thus acceleration is the rate at which vehicle speeds up/ slows down.
- Its dimensions being  $LT^{-2}$  is measured in meter per second square ( $m/s^2$ ).
- Acceleration of vehicle can be calculated by

$$F - \sum R = F_{net} = \gamma_m ma$$

- Where,  $F$ = Thrust of vehicle
  - $R$ = Total Resistance of Vehicle
  - $\gamma_m$  = Mass Factor
  - $m$ = mass of vehicle
  - $a$ = acceleration



$\gamma_m$  can be determined from the moments of inertia of the rotating parts by,

$$\gamma_m = 1 + \frac{\sum I_w}{mr^2} + \frac{\sum I_1 \xi_1^2}{mr^2} + \frac{\sum I_2 \xi_2^2}{mr^2} + \dots + \frac{\sum I_n \xi_n^2}{mr^2}$$

Where,

$I_w$  is the mass moment of inertia of the wheel,

$I_1, I_2 \dots I_n$  are the mass moments of inertia of the rotating components connected with the driveline having gear ratios  $\xi_1, \xi_2 \dots \xi_n$

- For passenger cars, the mass factor  $\gamma$ , may be calculated using the following empirical relation

$$\gamma_m = 1.04 + 0.0025 \xi_o^2$$

$\xi_o$  = Overall gear reduction ratio



- The tractive effort of the vehicle is given by,

$$F = \frac{M_e \xi_o \eta_t}{r}$$

$M_e$  is the engine output torque,

$\xi_o$  is the overall reduction ratio of the transmission (including both the gearbox and drive axle gear ratios),

$\eta_t$  is the overall transmission efficiency, and

$r$  is the radius of the tire



- The relationship between vehicle speed and engine speed is given by,

$$V = \frac{n_e r}{\xi_o} (1 - i)$$

$n_e$  = engine speed

$i$  = slip of the vehicle running gear.

- For a road vehicle, the slip is usually assumed to be 2-5% under normal operating conditions



- Rolling Resistance:

$$R_a = \frac{\rho}{2} C_D A_f V_r^2$$

Where,  $\rho$  is the mass density of the air,

$C_D$  is the coefficient of aerodynamic resistance

$A_f$  is a characteristic area of the vehicle, usually taken as the frontal area and

$V_r$  is the speed of the vehicle relative to the wind.



In the evaluation of acceleration time and distance, the engine is usually assumed to be operating at wide open throttle. It should be noted that a certain amount of time is required for gear changing during acceleration. For manual transmissions, gear changing causes a time delay of 1-2 s; for automatic transmissions, the delay is typically 0.5-1 s. To obtain a more accurate estimate of acceleration time and distance, this delay should be taken into consideration.

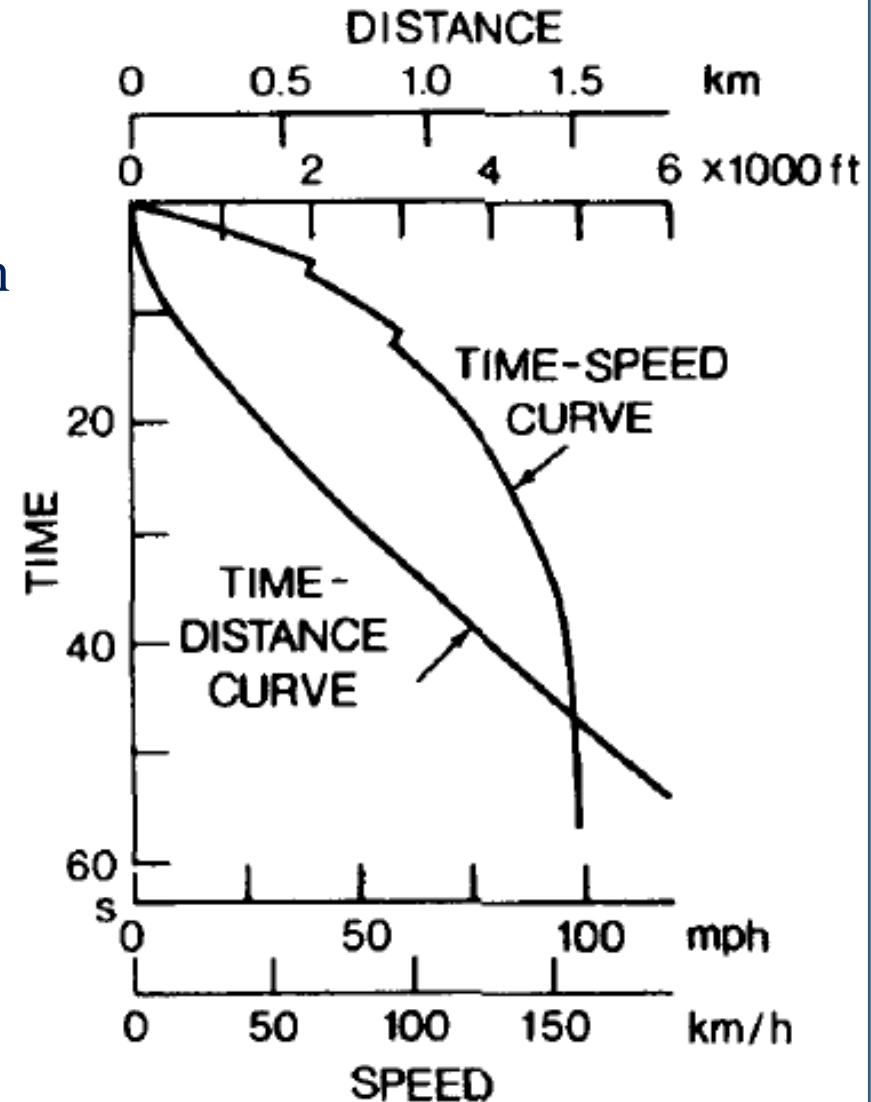



## ❖ Gradability:

- Gradability is usually defined as the maximum grade a vehicle can negotiate at a given steady speed.
- This parameter is primarily intended for the evaluation of the performance of heavy commercial vehicles and off-road vehicles.
- On a slope at a constant speed, the tractive effort has to overcome grade resistance, rolling resistance, and aerodynamic resistance:

$$F = W \sin \theta_s + R_r + R_a$$



Where,  $W$  = Normal load,  $\theta_s$  = slope angle,

$R_r$  = Rolling Resistance

$R_a$  = Aerodynamic Resistance

- For a relatively small angle of  $\theta_s$ ,  $\sin \theta_s = \tan \theta_s$
- Therefore, the grade resistance may be approximated by  $W \tan \theta_s$ , or  $WG$ , where  $G$  is the grade in percent.
- The maximum grade a vehicle can negotiate at a constant speed therefore is determined by the net tractive effort available at that speed:

$$G = \frac{1}{W} (F - R_r - R_a) = \frac{F_{\text{net}}}{W}$$

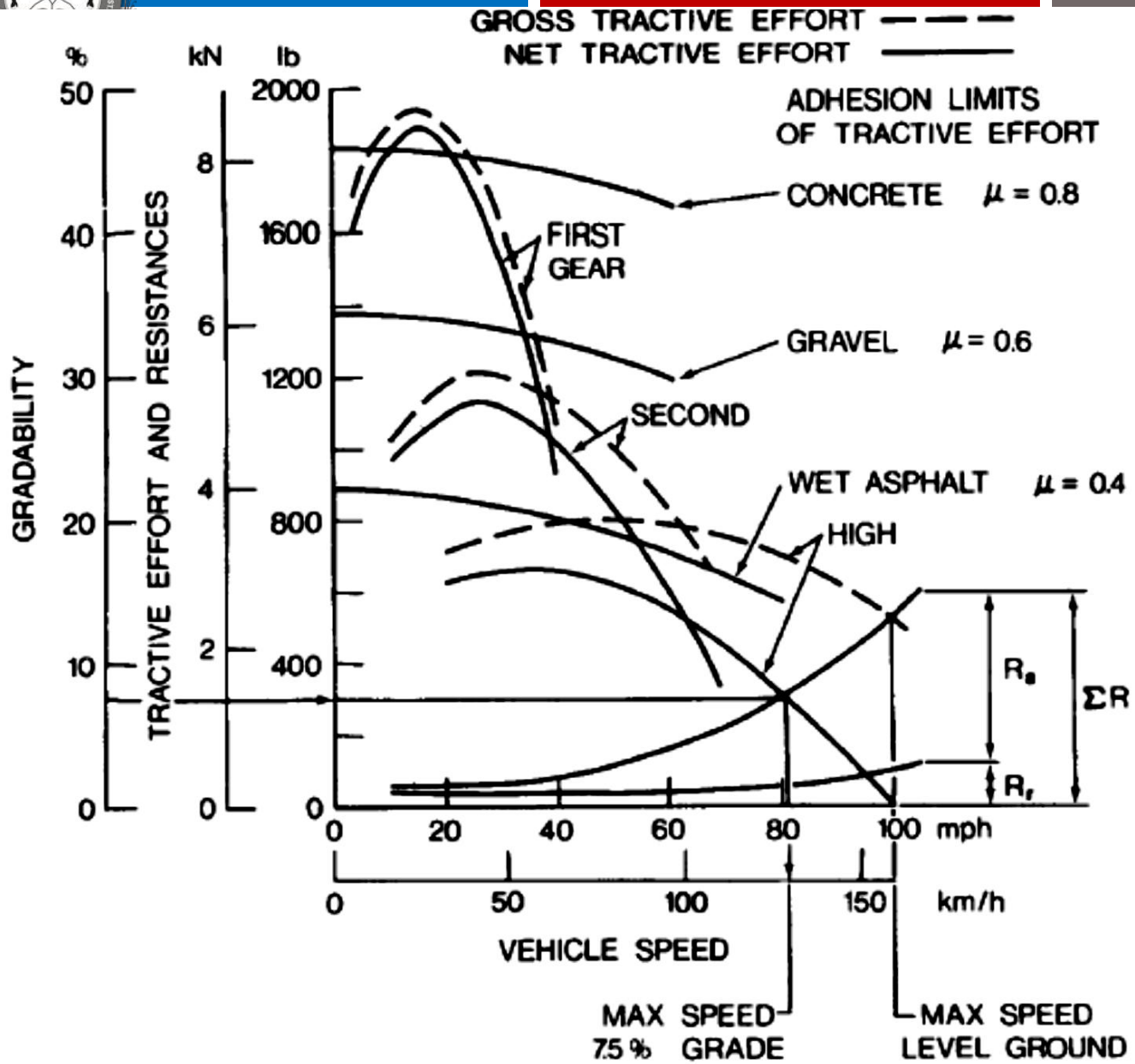

$$W = 17.79 \text{ kN}$$

$$G = 7.5\%$$

$$V = 133 \text{ km/h}$$



- For instance, the grade resistance of the passenger car with a weight of 17.79 kN (4000 lb) on a grade of 7.5% is 1.34 kN (300 lb).
- A horizontal line representing this grade resistance can be drawn on the diagram, which intersects that net tractive effort curve at a speed of 133 km/h (82 mph).
- This indicates that for the passenger car under consideration, the maximum speed obtainable at a grade of 7.5% is 133 km/h (82 mph).
- It should be noted that the limits of tractive effort set by the nature of tire-road adhesion usually determine the maximum gradability of the vehicle.
- For instance, it can be seen from Fig. above that the maximum grade the vehicle can negotiate at low speeds on a gravel surface with  $\mu = 0.6$  will be approximately 35%.



## ❖ Top Speed:

- The German Standard DIN 70020 defines top speed as the greatest speed that a vehicle can maintain over measured distance of 1 km.
- The test conditions are:
  1. Vehicle loaded with half load
  2. Level, dry surface with good grip,
  3. Max. wind speed  $\pm 3\text{m/s}$
  4. The vehicle must travel along the test track in both directions without interruption.

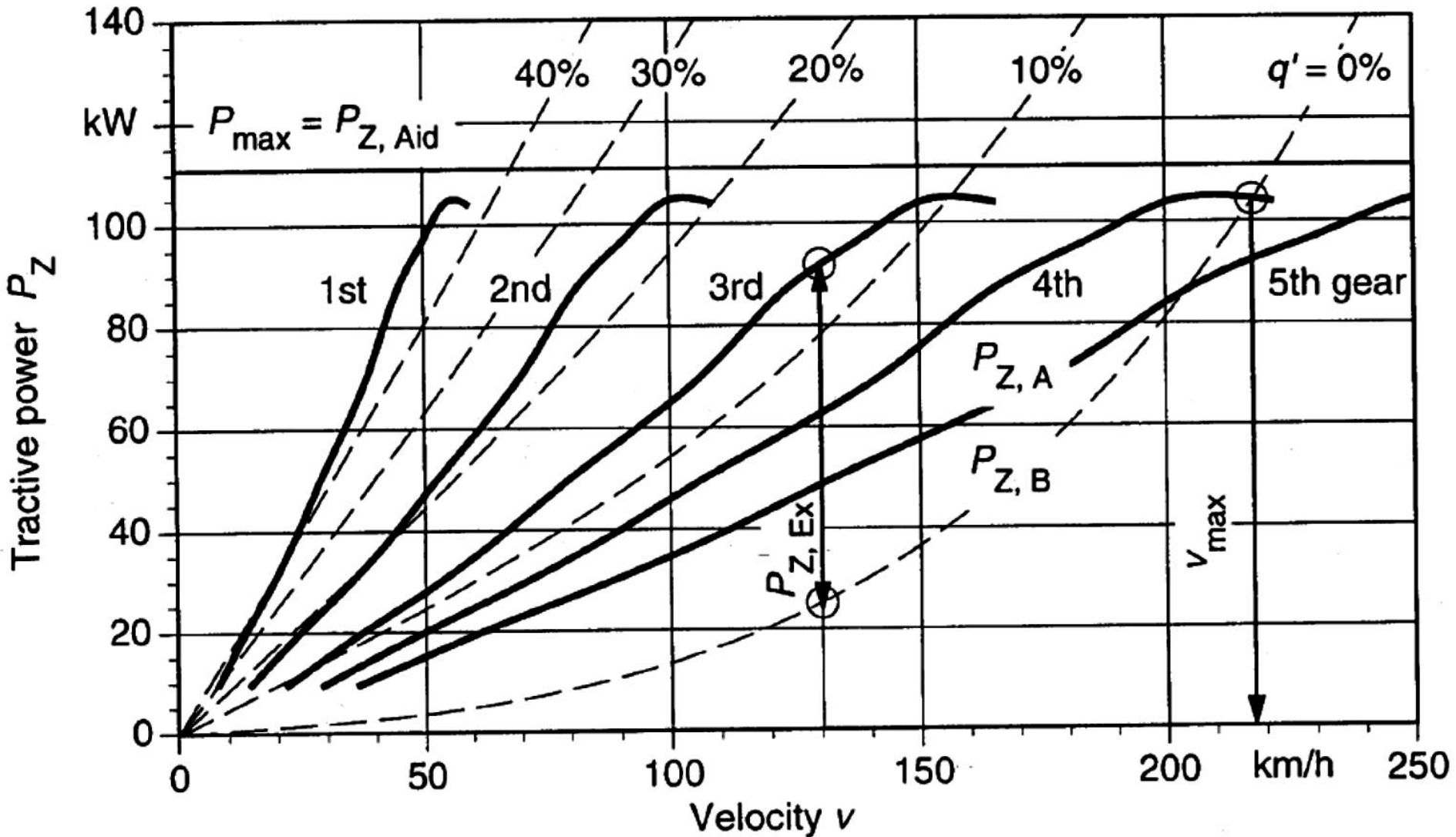





## ❖ **Braking Performance:**

- Braking performance of motor vehicles is undoubtedly one of the most important characteristics that affect vehicle safety.
- With increasing emphasis on traffic safety in recent years, intensive efforts have been directed towards improving the braking performance.
- Safety standards that specify performance requirements of various types of brake system have been introduced in many countries.
- The braking force  $F_b$  originating from the brake system and developed on the tire-road interface is the primary retarding force.



$h$  = height of CG

$L$  = wheelbase

$F_b$  = braking force

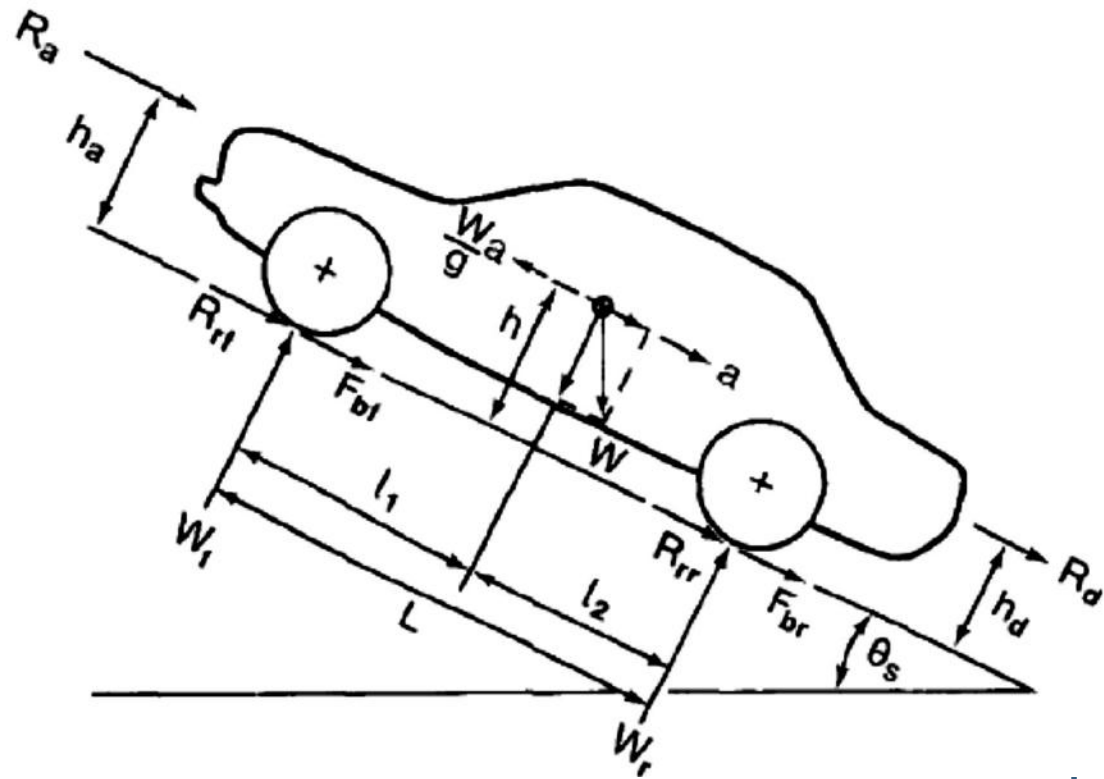

$l_1$  = distance between front axle and center of gravity of the vehicle

$l_2$  = distance between Rear axle and center of gravity of the vehicle



- When the braking force is below the limit of tire-road adhesion, the braking force  $F_b$  is given by,

$$F_b = \frac{T_b - \sum I\alpha_{an}}{r}$$

Where,  $T_b$  is the applied brake torque,

$I$  is the rotating inertia connected with the wheel being decelerated,

$\alpha_{an}$  is the corresponding angular deceleration,

and  $r$  is the rolling radius of the tire.



- During braking, there is a load transfer from the rear axle to the front axle.
- By considering the equilibrium of the moments about the front and rear tire ground contact points, the normal loads on the front and rear axles,  $W_f$  and  $W_r$  can be expressed as

$$W_f = \frac{1}{L} [Wl_2 + h(F_b + f_r W)]$$

and

$$W_r = \frac{1}{L} [Wl_1 - h(F_b + f_r W)]$$

- The maximum braking force that the tire-ground contact can support is determined by the normal load and the coefficient of road adhesion.
- With four-wheel brakes, the maximum braking forces on the front and rear axles are given by (assuming the maximum braking force of the vehicle  $F_{bmax} = \mu W$ )

$$F_{bfmax} = \mu W_f = \frac{\mu W [l_2 + h(\mu + f_r)]}{L} \dots \text{eqn.1}$$

$$F_{brmax} = \mu W_r = \frac{\mu W [l_1 - h(\mu + f_r)]}{L} \dots \text{eqn.2}$$

where,  $\mu$  is the coefficient of road adhesion

$f_r$  is the coefficient of rolling resistance

- It should be noted that when the braking forces reach the values determined by Eqn. 1 and 2, tires are at the point of sliding.
- Any further increase in the braking force would cause the tires to lock up.

$$\frac{K_{bf}}{K_{br}} = \frac{F_{bf\max}}{F_{br\max}} = \frac{l_2 + h(\mu + f_r)}{l_1 - h(\mu + f_r)}$$

Where,  $K_{bf}$  and  $K_{br}$  are the proportions of the total braking force on the front and rear axles, respectively, and are determined by the brake system design.



- For instance, for a light truck with 68% load on rear axle ( $l_2/L = 0.32$ ,  $l_1/L = 0.68$ ),  $h/L = 0.18$ ,  $\mu = 0.85$ , and  $f_r = 0.01$ , the maximum braking forces of the front and rear tires that the tire-ground contact can support will be developed at the same time only if the braking force distribution between the front and rear brakes satisfies the following condition:

$$\frac{K_{bf}}{K_{br}} = \frac{0.32 + 0.18(0.85 + 0.01)}{0.68 - 0.18(0.85 + 0.01)} = \frac{47}{53}$$

- In other words, 47% of the total braking force must be placed on the front axle and 53% on the rear axle to achieve optimum utilization of the potential braking capability of the vehicle.



- The braking force distribution that can ensure the maximum braking forces of the front and rear tires developed at the same time is referred to as the ideal braking force distribution.
- If the braking force distribution is not ideal, then either the front or the rear tires will lock up first.
- When the rear tires lock up first, the vehicle will lose directional stability.
- When the rear tires lock, the capability of the rear tires to resist lateral force is reduced to zero.

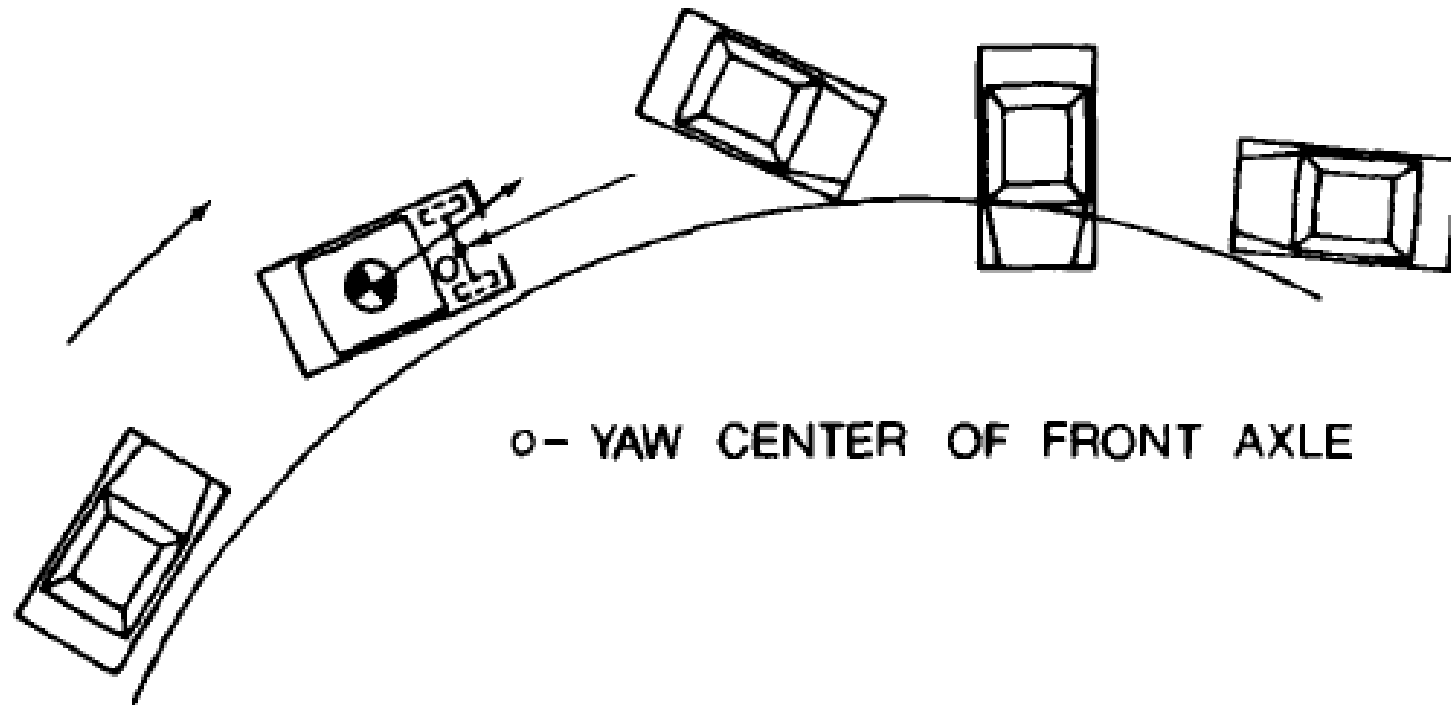

- If some slight lateral movement of the rear tires is initiated by side wind, road camber, or centrifugal force, a yawing moment due to the inertia force about the yaw center of the front axle will be developed





- As the yaw motion progresses, the moment arm of the inertia force increases, resulting in an increase in yaw acceleration.
- As the rear end of the vehicle swings around  $90^\circ$ , the moment arm gradually decreases, and eventually the vehicle rotates  $180^\circ$ , with the rear end leading the front end.
- The lock-up of front tires will cause a loss of directional control, and the driver will no longer be able to exercise effective steering.
- However, that front tire lock-up does not cause directional instability.
- Rear tire lock-up is a more critical situation, particularly on a road surface with a low coefficient of adhesion.



## ❖ Ride Comfort:

- Customer expectations of smooth running are high, especially in case of cars, passenger bus etc.
- Ride quality is concerned with the sensation or feel of the passenger in the environment of a moving vehicle.
- **Ride quality** refers to the degree of protection offered vehicle occupants from uneven elements in the road surface, or the terrain if driving off-road. A car with very good **ride quality** is also a **comfortable** car to **ride** in.
- Ride comfort problems mainly arise from noise and vibrations of the vehicle body,
  - Surface irregularities (potholes to random variations),
  - Aerodynamic forces,
  - Noise and vibrations of the engine and driveline, and
  - Non uniformities (imbalances) of the tire/wheel assembly.

- Passenger ride comfort (or discomfort) boundaries are difficult to determine because of the variations in individual sensitivity to vibration and of a lack of a generally accepted method of approach to the assessment of human response to vibration.
- Considerable research work has been conducted by different investigators to define ride comfort.
- Mechanical substitute models of the power train

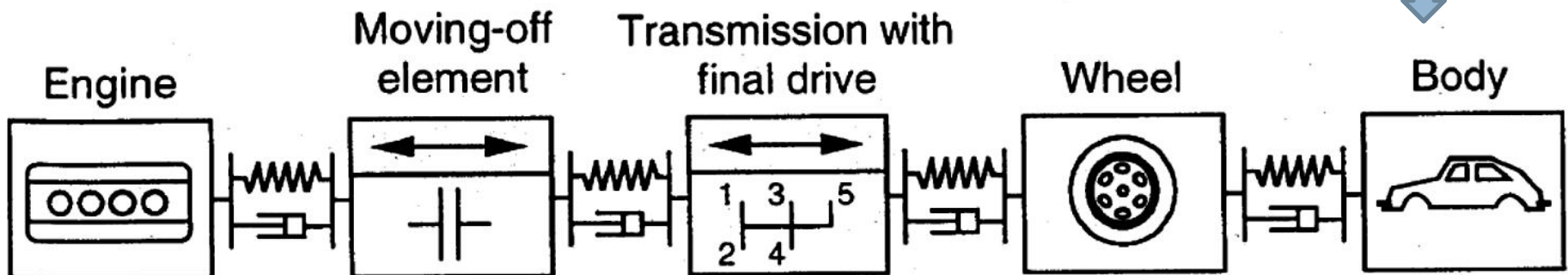

- A variety of methods for assessing human tolerance to vibration have been developed over the years:
  - *Subjective Ride Measurements.*
  - *Shake Table Tests.*
  - *Ride Simulator Tests.*
  - *Ride Measurements in Vehicles.*

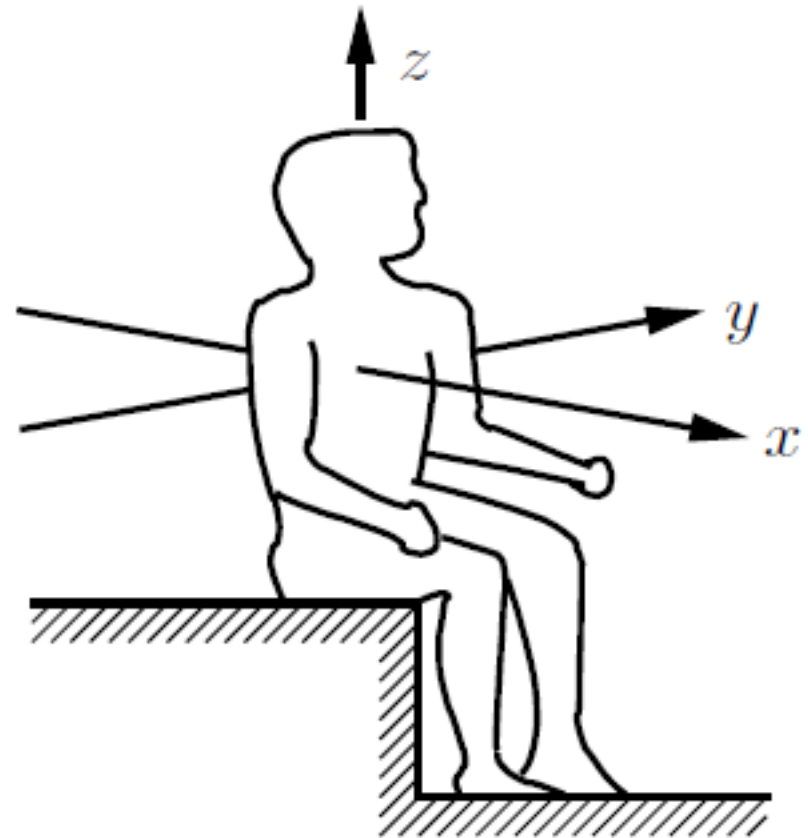



## 1. *Subjective Ride Measurements.*

- The traditional technique for comparing vehicle ride quality in the automotive industry in the past is to use a trained jury to rate the ride comfort, on a relative basis, of different vehicles driven over a range of road surfaces.
- With a large enough jury and a well-designed evaluation scheme, this method could provide a meaningful comparison of the ride quality of different vehicles.
- The degree of difference in ride quality, however, cannot be quantitatively determined by this type of subjective evaluation.



## *2. Shake Table Tests.*

- In an attempt to quantitatively study human response to vibration, a large number of shake table experiments have been performed over the years.
- Most of this research pertains to human response to sinusoidal excitation.
- It is intended to identify zones of comfort (or discomfort) for humans in terms of vibration amplitude, velocity, or acceleration in a given direction (such as foot-to-head, side-to-side, or back-to-chest) over a specific frequency range.



### ***3. Ride Simulator Tests.***

- In these tests, ride simulators are used to replicate the vibration of the vehicle traveling over different road surfaces.
- In some facilities, an actual vehicle body is mounted on hydraulic actuators, which reproduce vehicle motions in pitch, roll, and bounce (or heave). Road inputs are fed into the actuators.
- Using the simulator, it is possible to establish a human tolerance limit in terms of vibration parameters.



## ***4. Ride Measurements in Vehicles.***

- Shake table tests and ride simulator tests described above are conducted under laboratory conditions. They do not necessarily provide the same vibration environments to which the passenger is subject while driving on the road.
- Therefore, on-the road ride measurements, particularly for passenger cars, have been performed.
- This test method attempts to correlate the response of test subjects in qualitative terms, such as "unpleasant" or "intolerable," with vibration parameters measured at the location where the test subject is situated under actual driving conditions.



## ❖ Handling Characteristics:

- Vehicle handling is indicator that shows that the vehicle behavior on the road.
- Handling characteristics of vehicles are closely related to driving safety.





- Handling characteristics of road vehicles refer to its response to steering commands and to environmental inputs, such as wind gust and road disturbances that affect its direction of motion.
- Many traffic accidents are caused by undesired and unexpected handling behavior of vehicle.
- Hence it is necessary to understand the handling characteristics of vehicle



- Handling issue comes into light at the time of cornering and swerving (sharp turn).
- It is commonly judged by how a vehicle performs particularly during **cornering, acceleration, and braking as well as on the vehicle's directional stability** when moving in steady state condition.



## **Factors that affect a Vehicle's handling:**

1. Weight distribution
2. Height of Center of Gravity
3. Center of Gravity
4. Suspension
5. Steering
6. Spring Rate
7. Suspension travel
8. Tire and wheels



## ❖ Life Durability:

- **Durability:** System is durable when it performs or does not fail beyond its expected life, examples of durability:
  - A car does not need any repair during warranty period of 3 years
  - A car is still on the road after 10 years
  - A car is still on the road after 200,000 km
- The ability of a product to perform its required function over a lengthy period under normal conditions of use without excessive expenditure on maintenance or repair
- Ability to withstand to fatigue, corrosion, wear, creep, ...
- Customer expects a good lifespan and durable vehicle without major defects and repair.

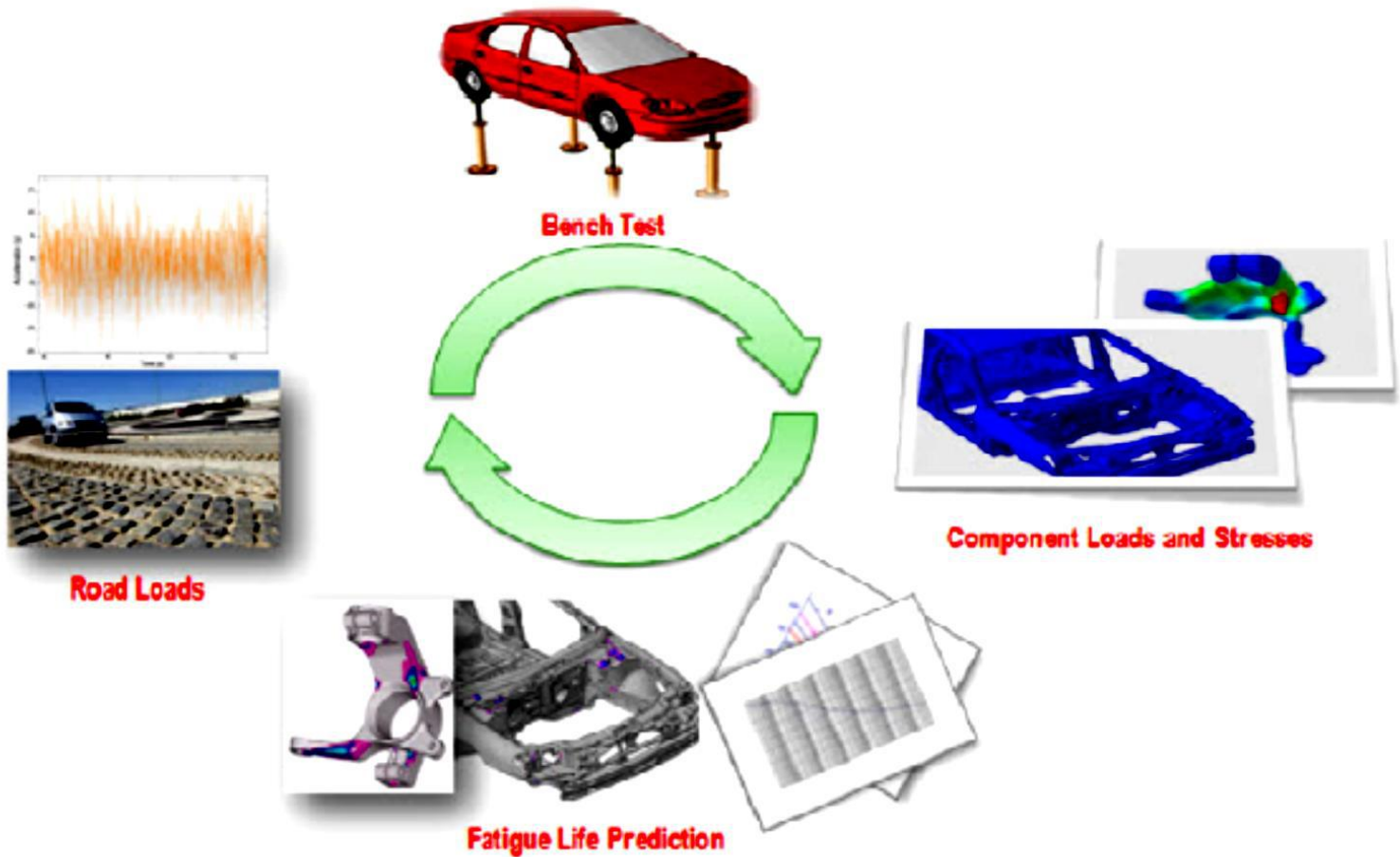

# Fatigue Life Estimation

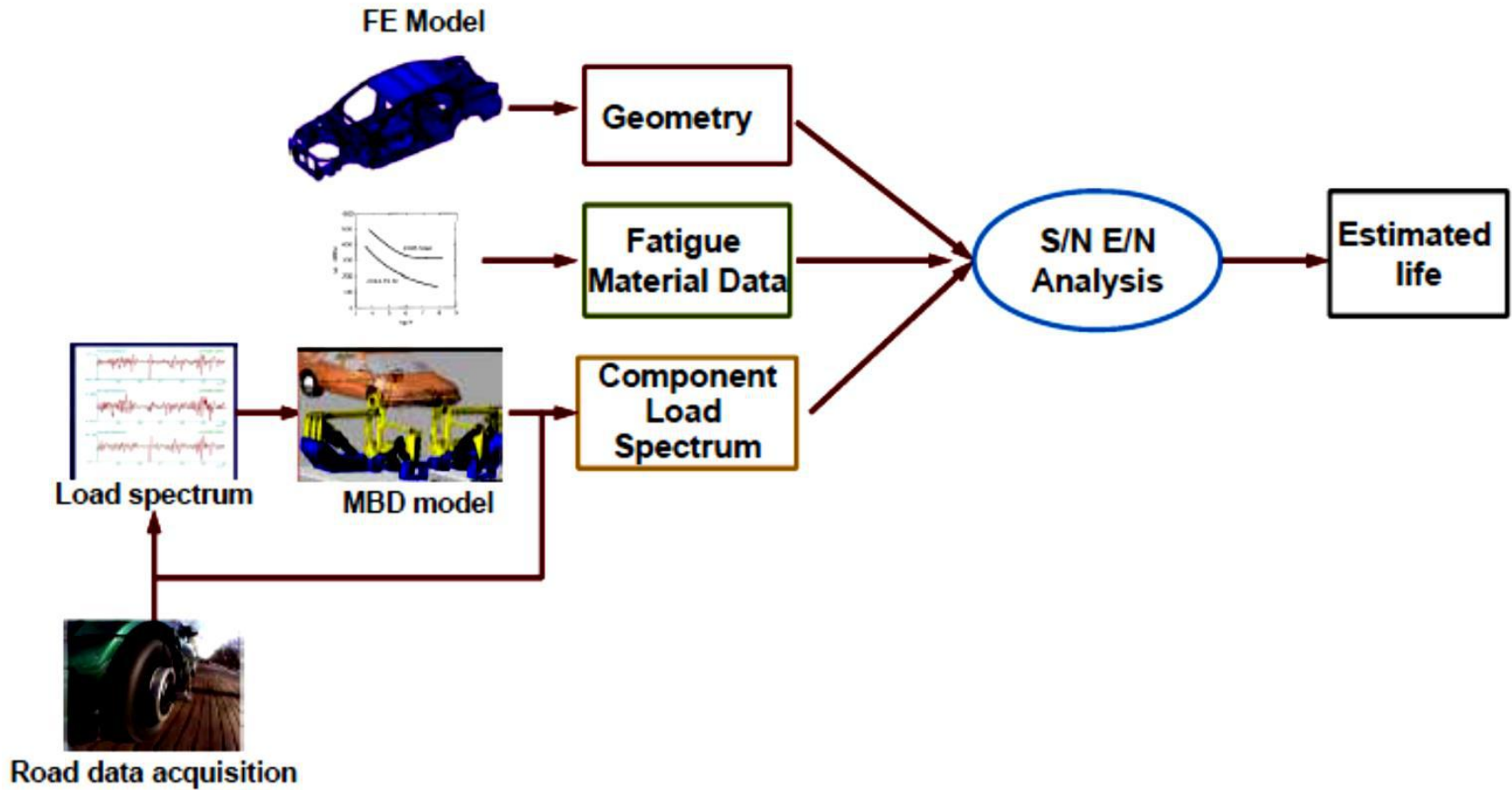

## ❖ EGR Systems:

- Exhaust Gas Recirculation (EGR) systems effectively reduce Nox emissions by recirculating a portion of the exhaust gas and mixing it with the intake air to lower the burning temperature. A computer automatically controls the EGR amount in accordance with the engine load or speed.

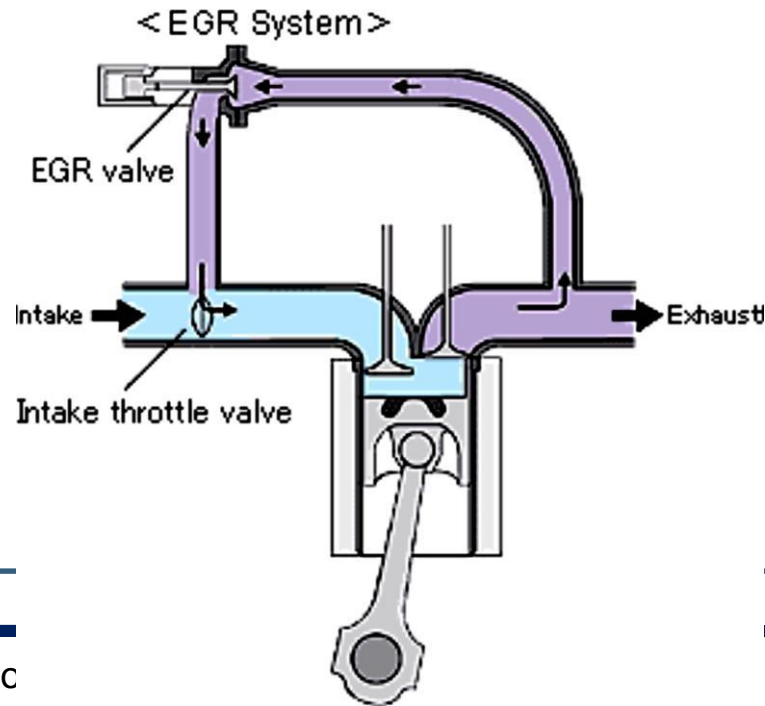





- Continuous Control EGR System (for Light Duty Trucks) employ a continuous control system for the EGR valve.
- This system contributes to Nox reduction by electronically controlling the EGR volume and the intake air amount through linkage with the EGR valve and intake system.

- Exhaust gas is taken from exhaust manifold and is Cooled sometimes.
- Exhaust gas is added to the intake manifold and is controlled by some means :
  - ECM determines volume
  - EGR Valve controls
- Mixture of exhaust gas and fresh air is used in combustion cycle

Cooled-EGR Schematic

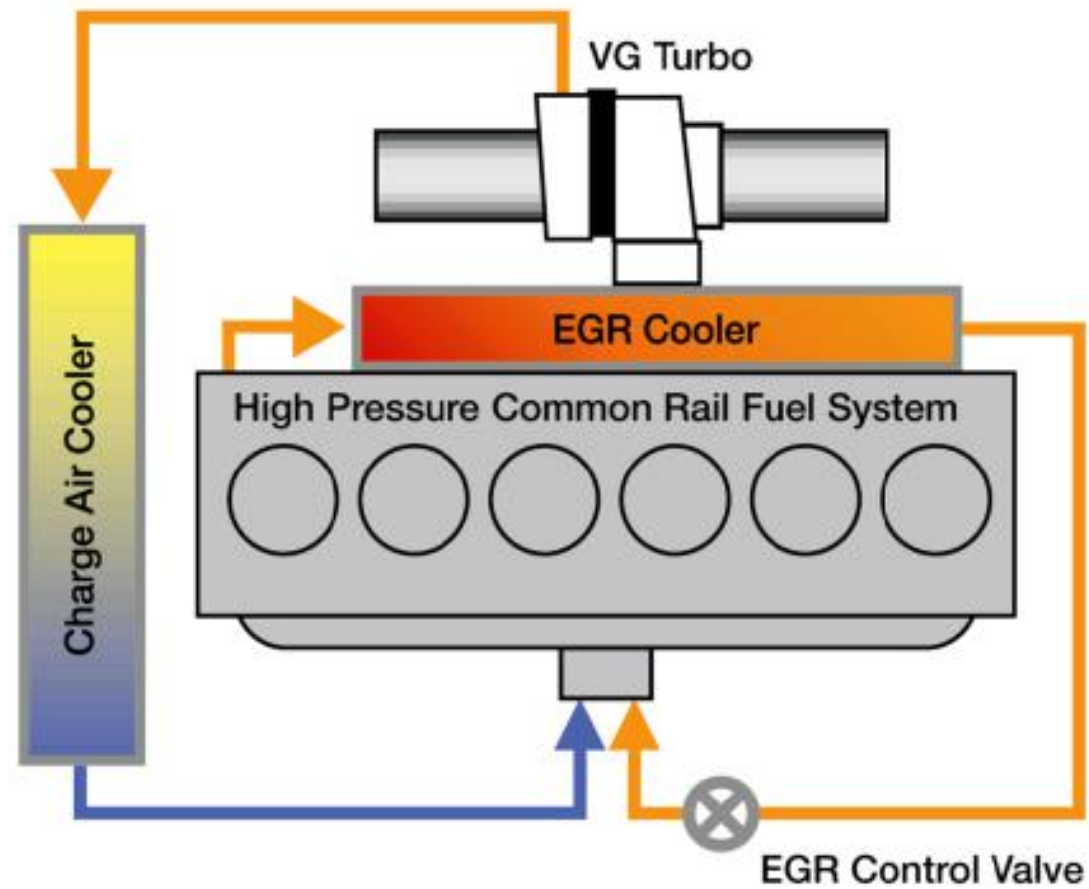

## Effect of EGR

- ❑ Replacement of air by inert combustion products
- ❑ Exhaust gas has higher specific heat than air
- ❑ Reduce in-cylinder oxygen content
- ❑ Reduced temperature in the combustion chamber
- ❑ Nox reduces, PM increases

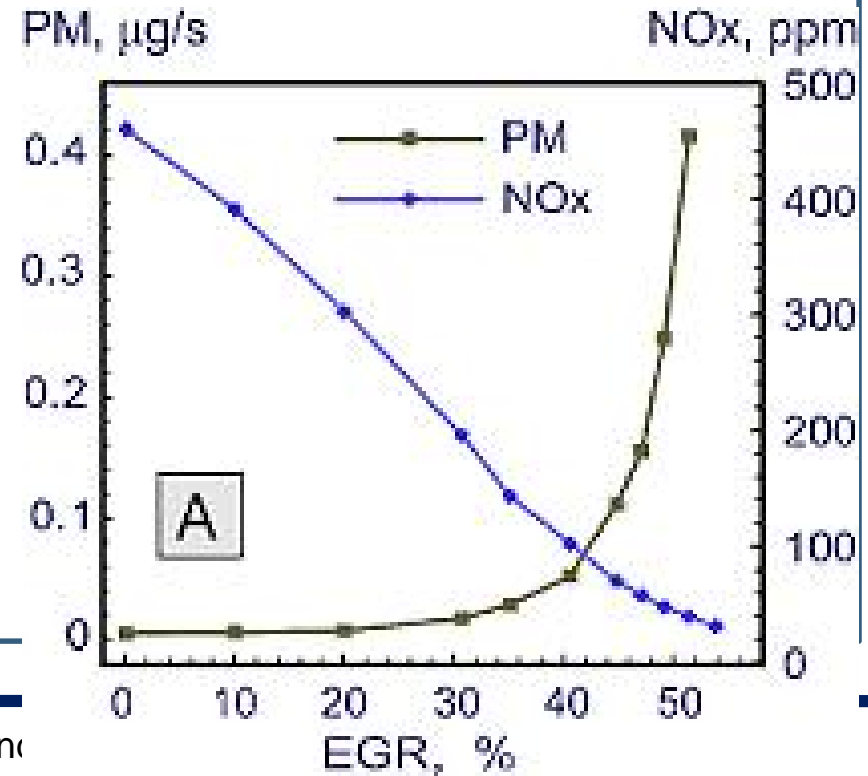



## ❖ **Types of EGR**

- Internal EGR
- External EGR
- Hot EGR
- Cooled EGR
- Partially cooled EGR
- High pressure EGR
- Low pressure EGR

- **High pressure EGR**

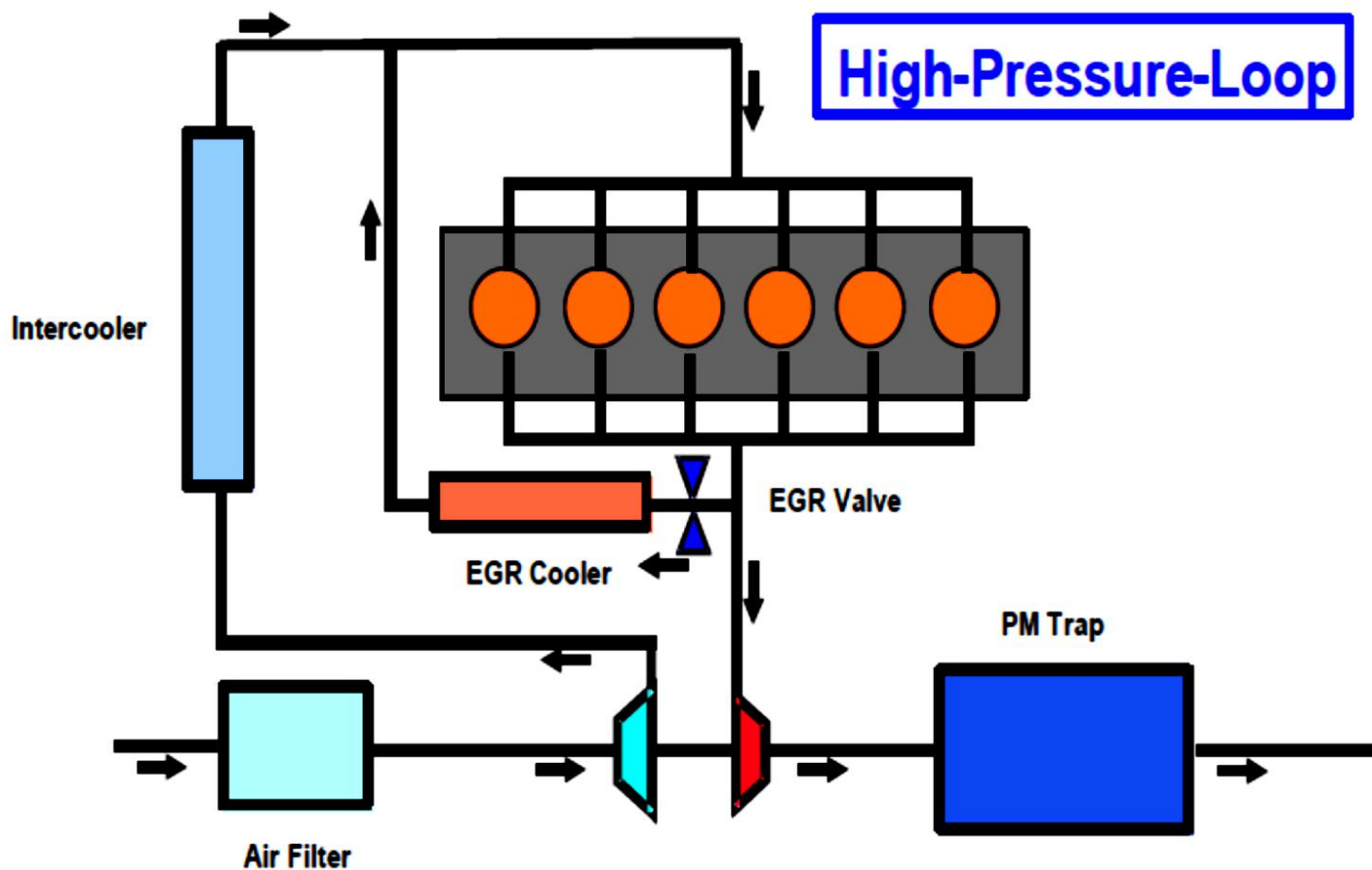

- Low pressure EGR**

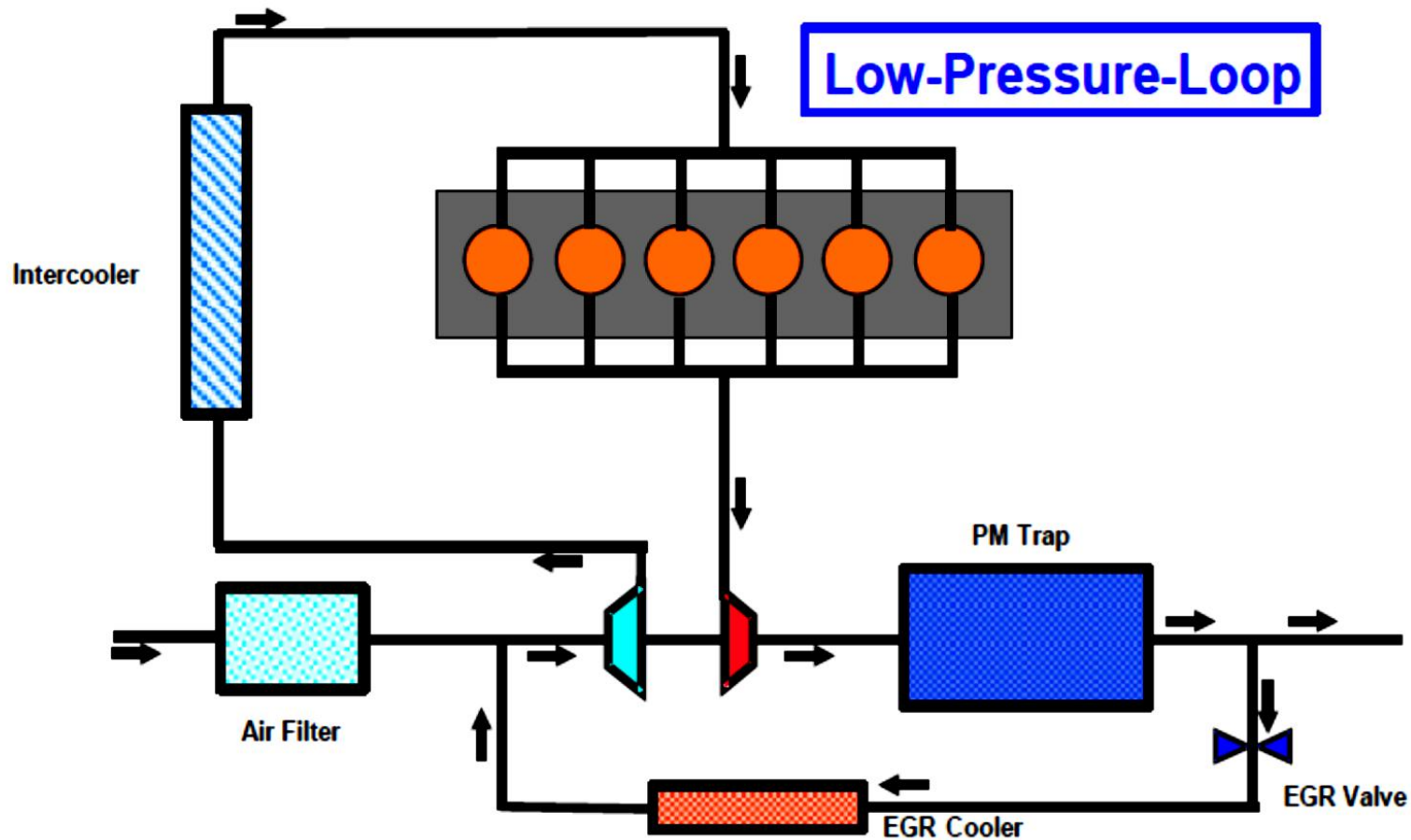

## ❖ Catalytic Converter:

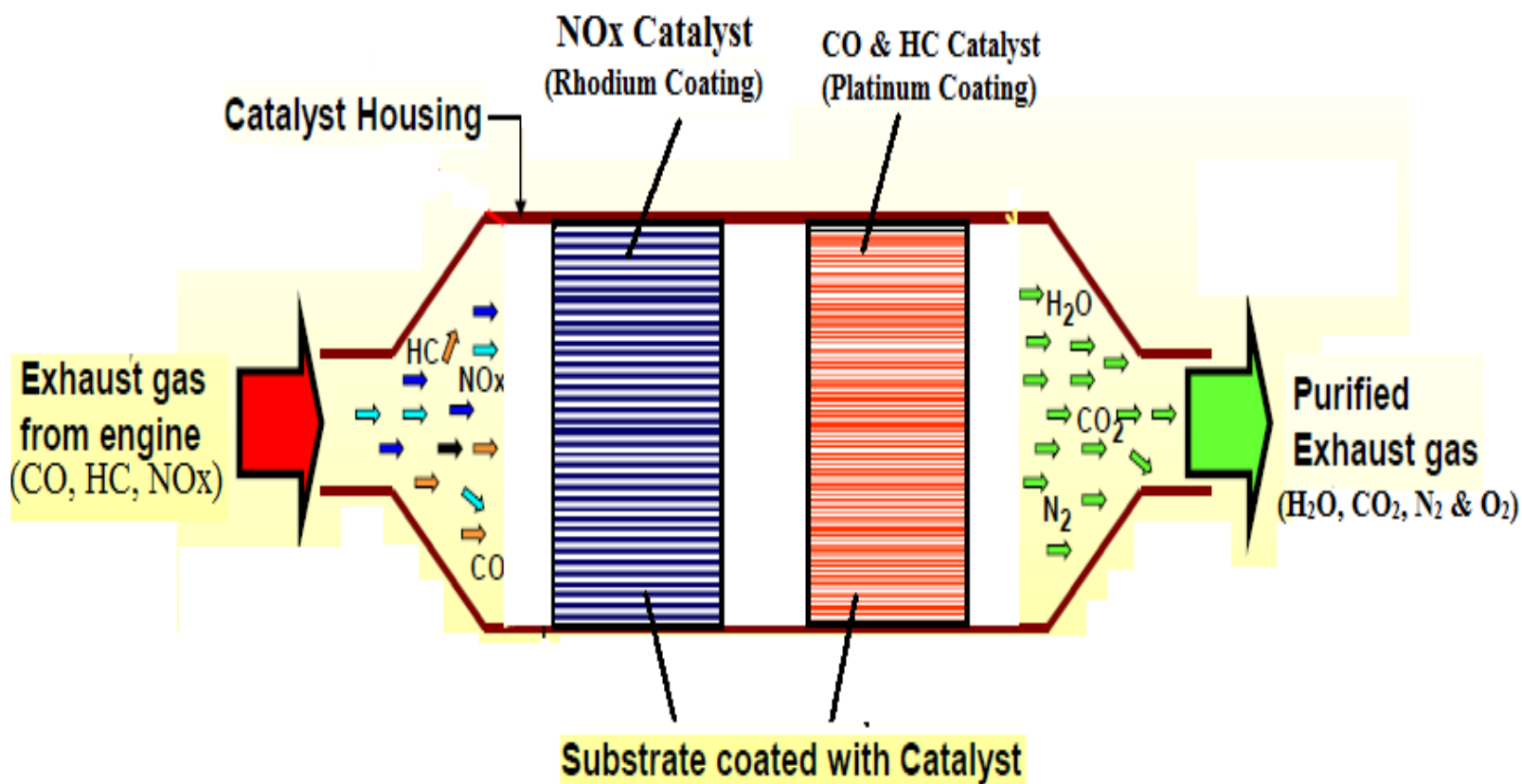



- It is device which utilises a catalyst (made up of 3 noble materials) to convert three harmful emissions (CO, HC and NO<sub>x</sub>) from an automobile to harmless components. The three noble materials are known as Platinum Group Materials (PGM). These includes Platinum (Pt), Palladium (Pd) and Rhodium (Rh).
- The catalytic converter consists of a honeycomb like structure enclosed into one housing (known as Can). The honeycomb structure is called as “Substrate”. The substrate is core of catalytic converter which provides high geometric surface area, so that the conversion efficiency can be increased.





- The substrate can be made up of Metal or Ceramic (e.g. Silicon Carbide (SiC), Zirconia (ZrO<sub>2</sub>) etc.). The substrate is coated with the platinum, palladium and rhodium materials.
- The catalyst material transforms the harmful emissions into harmless components by two chemical processes viz., Oxidation and Reduction.
- In oxidation, it converts CO into CO<sub>2</sub> by addition of O<sub>2</sub>, also it converts HC into CO<sub>2</sub> and water vapours by addition of O<sub>2</sub>. So it is known as oxidation process. The **Platinum** and **Palladium** catalysts are used for oxidation process.



- The chemical reactions are given below,



- In reduction process, it converts NO (Nitrogen oxide) to N<sub>2</sub> (Nitrogen) by reducing or removing the oxygen. So it is known as reduction process. For this, the **Rhodium** catalyst is used which reduces the nitrogen oxides to nitrogen gas.



# Catalyst Light-off:

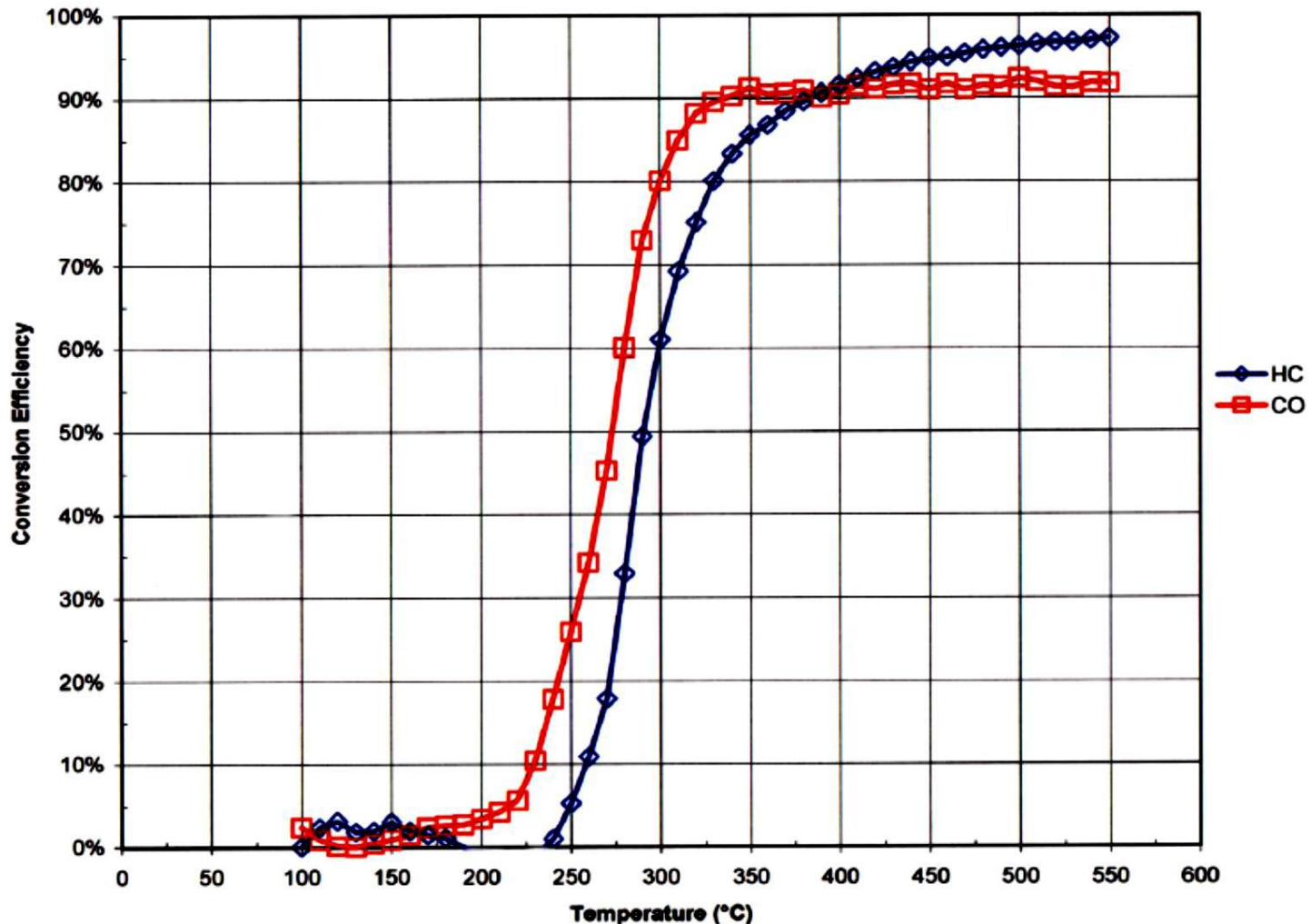

## Solution: Electrically Heated Substrate



## Types of Substrates:

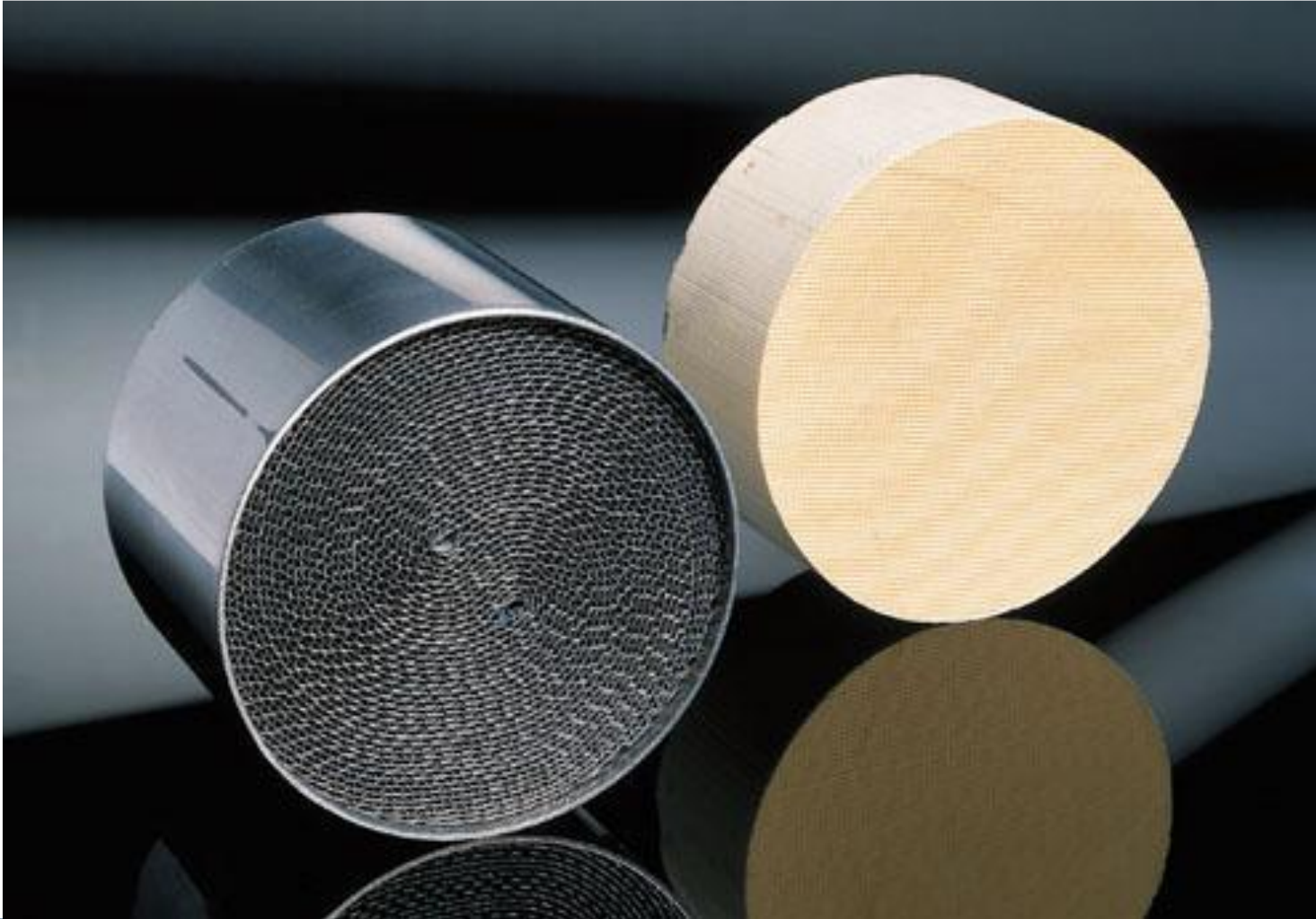



## Ceramic Substrate

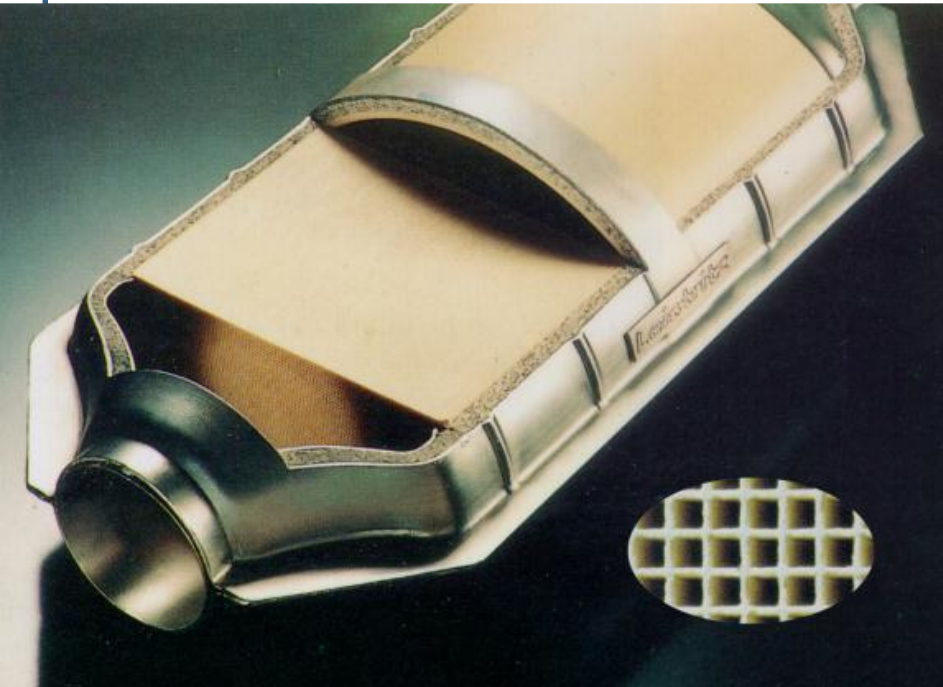

## Metallic Substrate





## Comparison:

	Ceramic	Metal	Advantage Metal
Wall Thickness (mm)	0.16	0.05	Lower Pressure Drop
Clear Cross Section (%)	76	90	Lower Back Pressure
Geometrical Surface Area (m <sup>2</sup> /l)	2.8	3.5	More Conversion Efficiency
Specific Heat Capacity (kJ/Kg/K)	1.1	0.5	Faster Light Off
Thermal Conductivity (W/mK)	1	14	Better Heat Dissipation

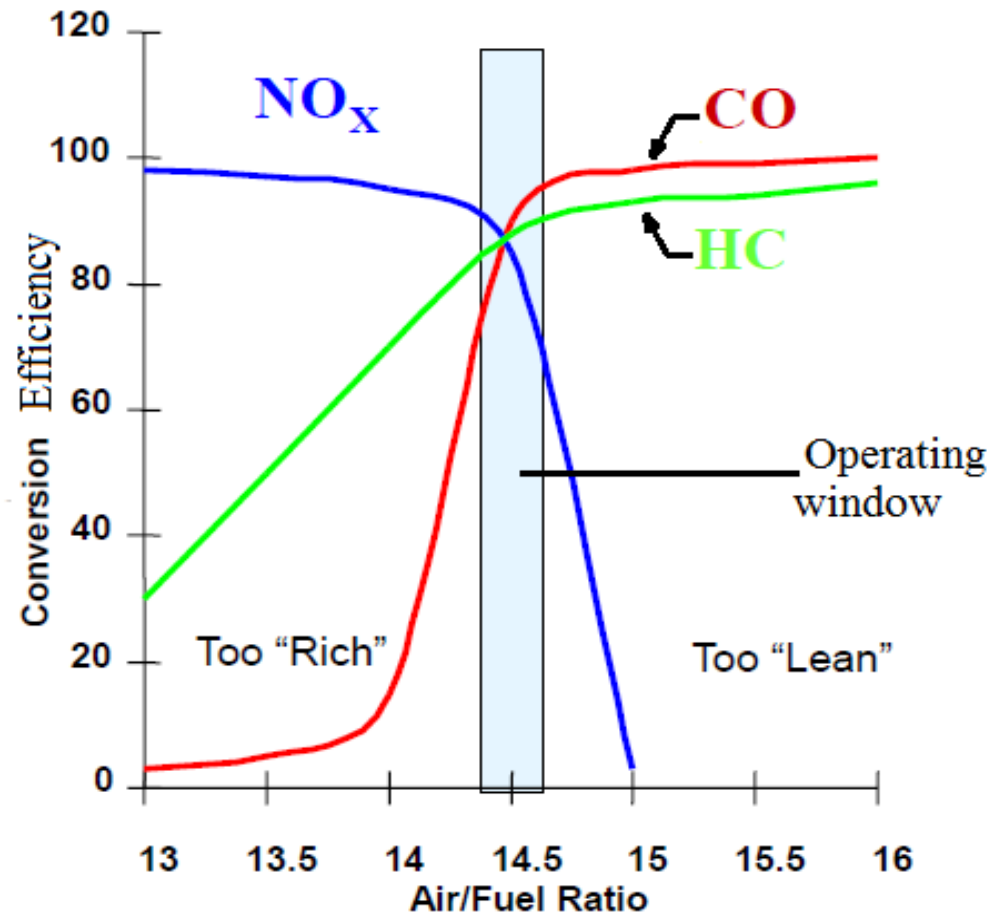

- The conversion efficiency of a catalytic converter will be higher when the engine will run in a very small window of stoichiometric ratio (0.1 air/fuel ratio)





- The conversion efficiency of a TWC depends mostly air/fuel ratio (Window of  $\pm 0.05$  air/fuel ratio)
- Controlling the average air/fuel ratio to the tolerances of the TWC window requires accurate and precise measurements of air flow rate and precise fuel delivery.
- This precise measurements can be obtained by electronic engine control system.

## ❖ Lambda Closed Loop Control System:

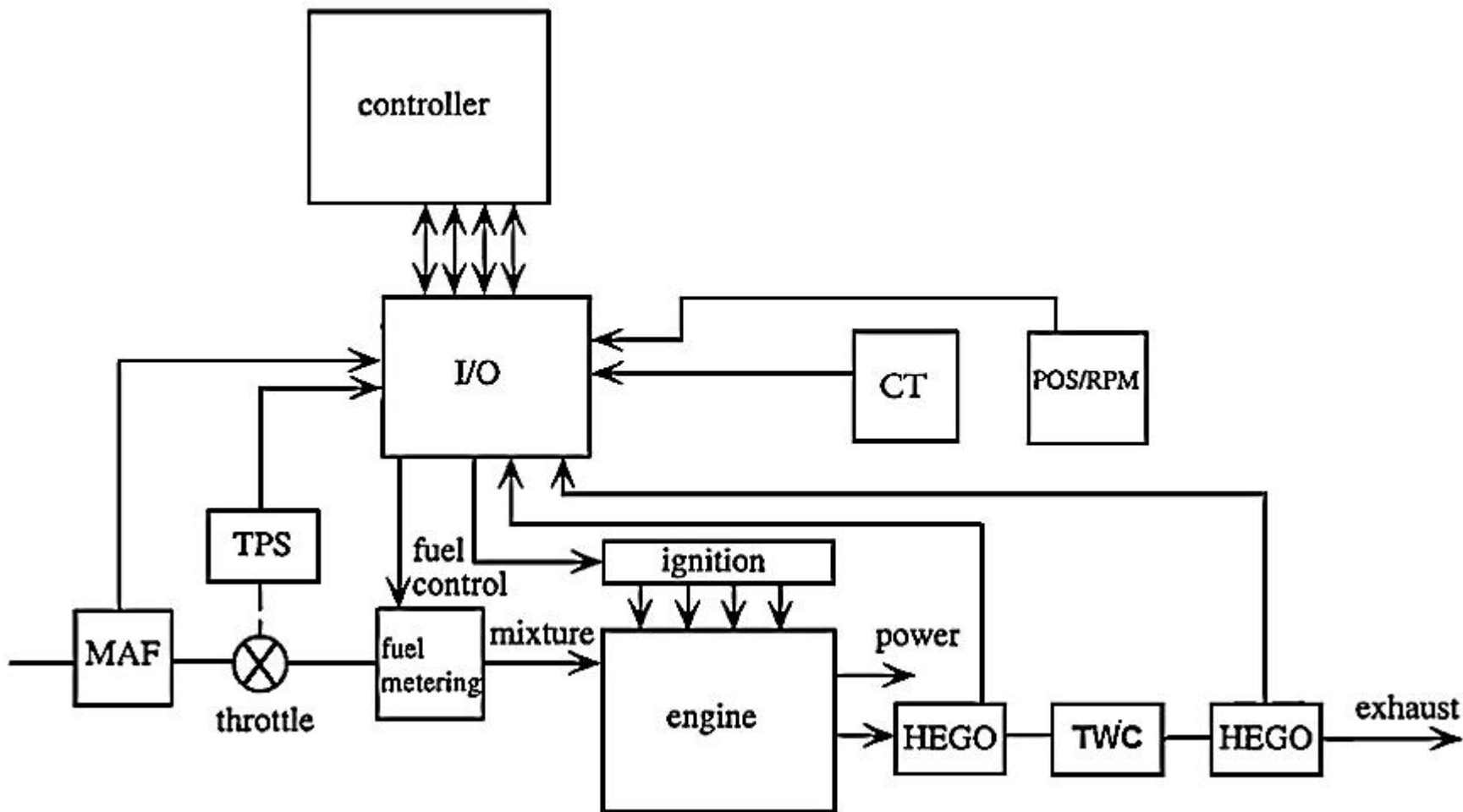



MAF- Mass Air Flow Sensor

TPS- Throttle Position Sensor

HEGO- Heated Exhaust Gas Oxygen Sensor

CT- Coolant Temperature Sensor

TWC- 3 way Catalyst

POS/RPM- Position Sensor (Crankshaft RPM)

$$\lambda = \frac{\text{air/fuel}}{\frac{\text{air}}{\text{fuel}} \text{stoichiometry}}$$

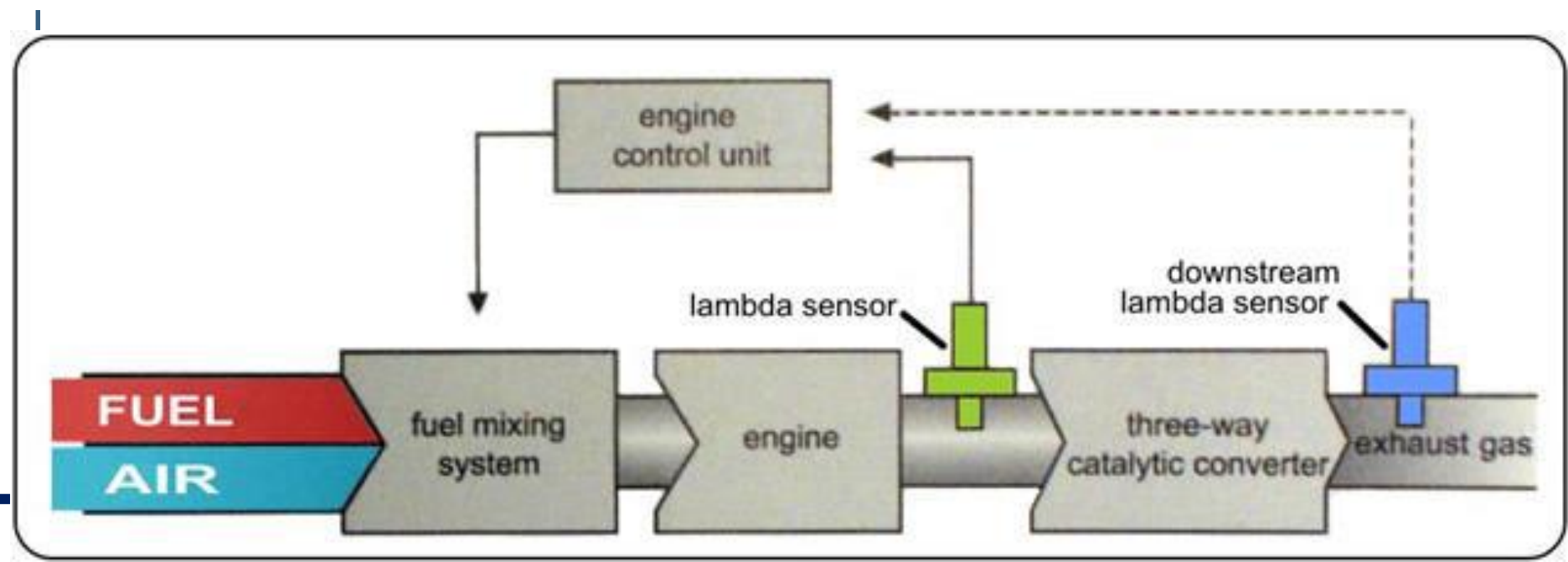
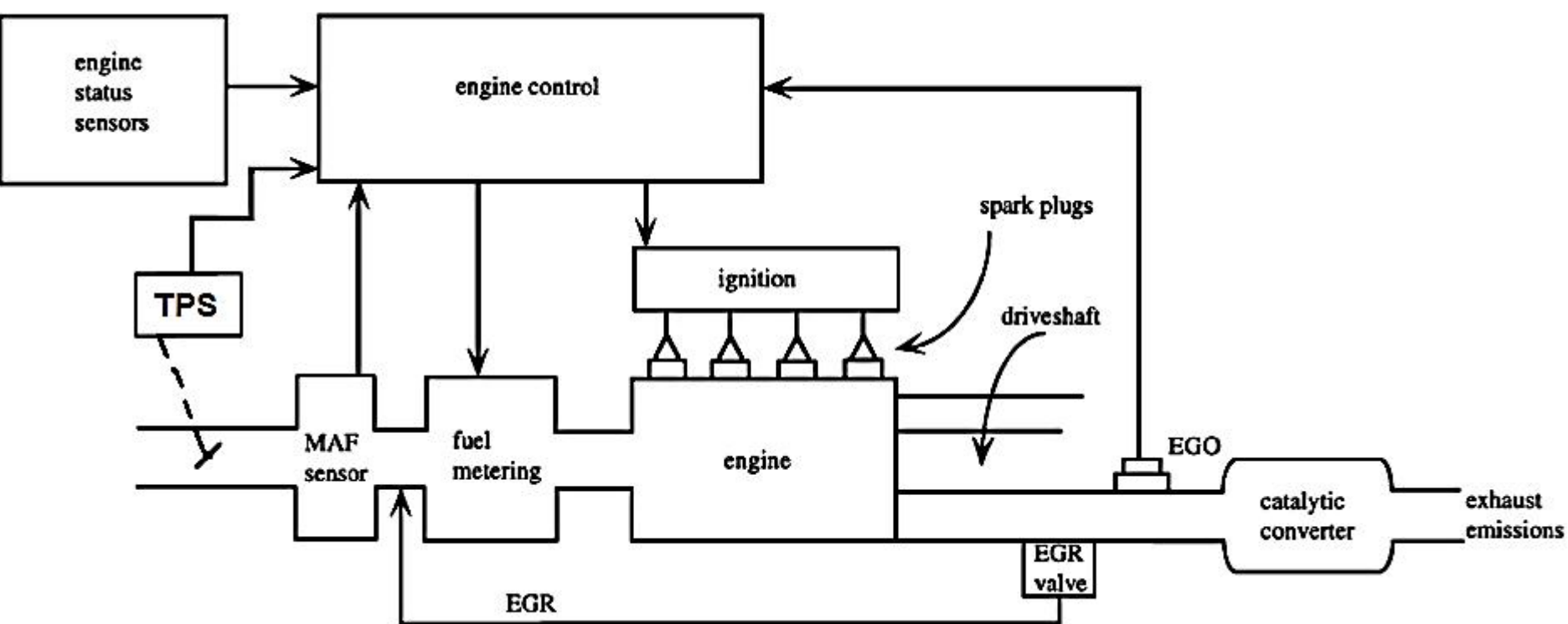



- An average ECU using a **narrowband sensor** will generally only use the lambda sensor's output during two specific conditions:-
  - (a) during idle, i.e.. when the engine is under no load apart from keeping itself running, and
  - (b) during part-load conditions (which we usually term 'cruising speed') where the engine is keeping the car at a constant speed.
- A car equipped with a **wideband sensor** is able to usefully use the lambda signal over a wider range of operating conditions but it is still mostly utilized around stoichiometry or during lean-burn operation.



- The ECU will generally ignore the (narrowband) lambda sensor's output during three conditions:-
  - (c) when the car is accelerating - the ECU will spend much of its time deliberately enriching the mixture to avoid hesitation and to provide extra power, and
  - (d) when decelerating or 'engine braking', when most ECU's will shut off the fuel completely to aid economy.
  - (e) In case of cold starting

## Look-up Table:

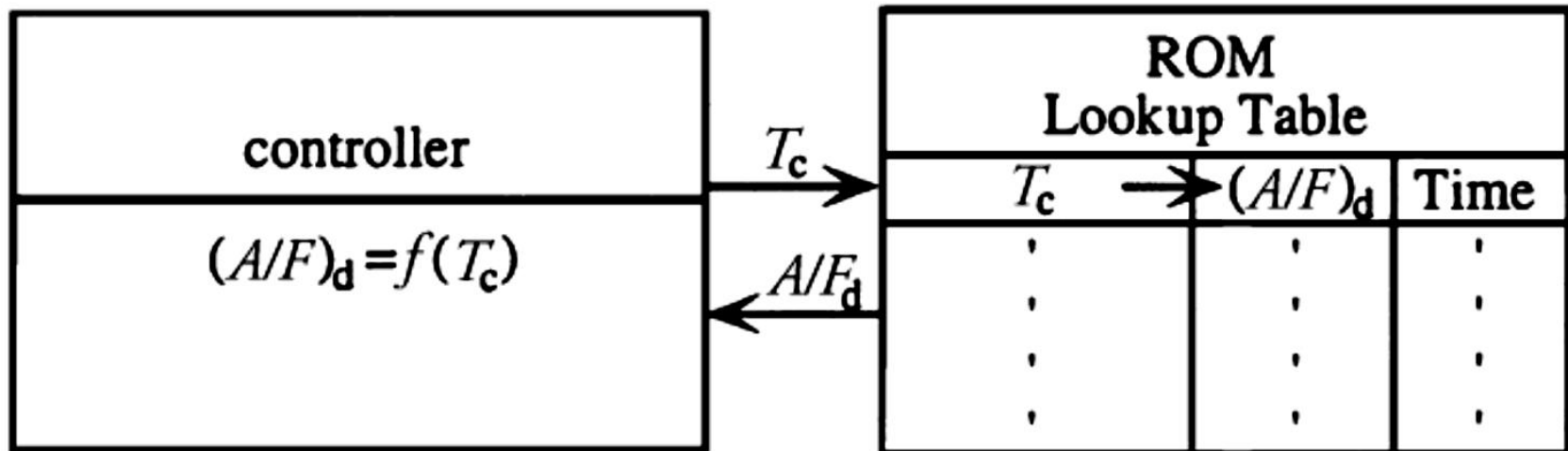

# Success Story of Catalyst

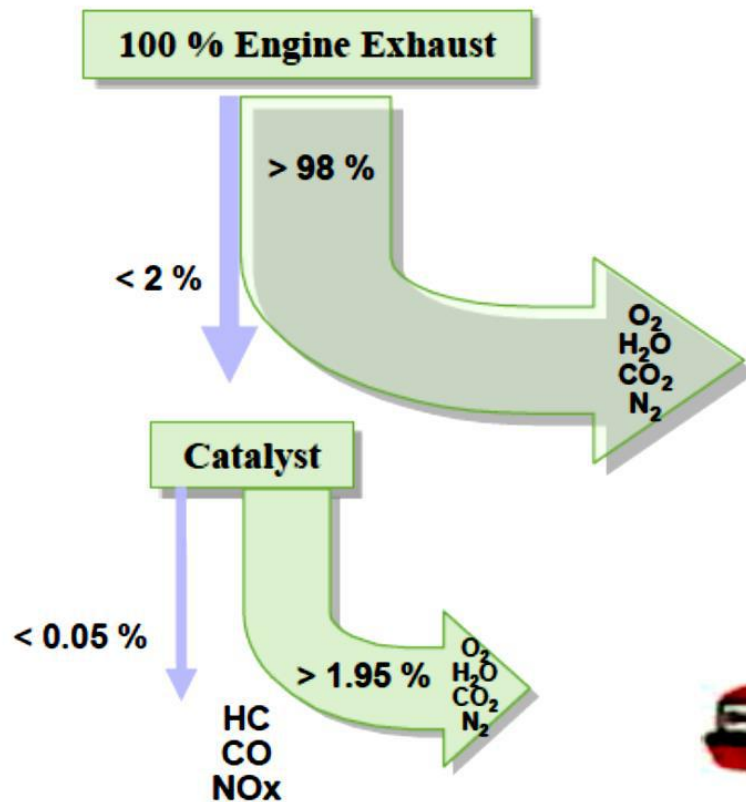

The development of automotive emission control technology over the last three and a half decades is one of the greatest environmental success stories of this century.

Compared to the 1960s the emission of motor vehicles has dropped to a fraction, the fuel economy has doubled.





